

CUSTOMER DRAWING

REV.	DATE	D.C.N. NUMBER	DESCRIPTION	CHECKED BY DATE	APPROVED BY DATE
1	23/10/09		FIRST ISSUE	AB 23/10/09	MB 23/10/09

PCB HOLE & GLUE PAD LOCATION

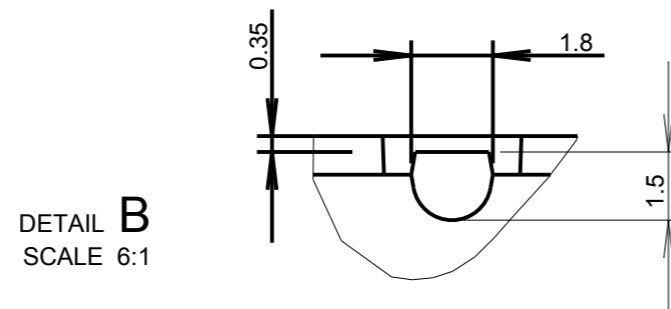
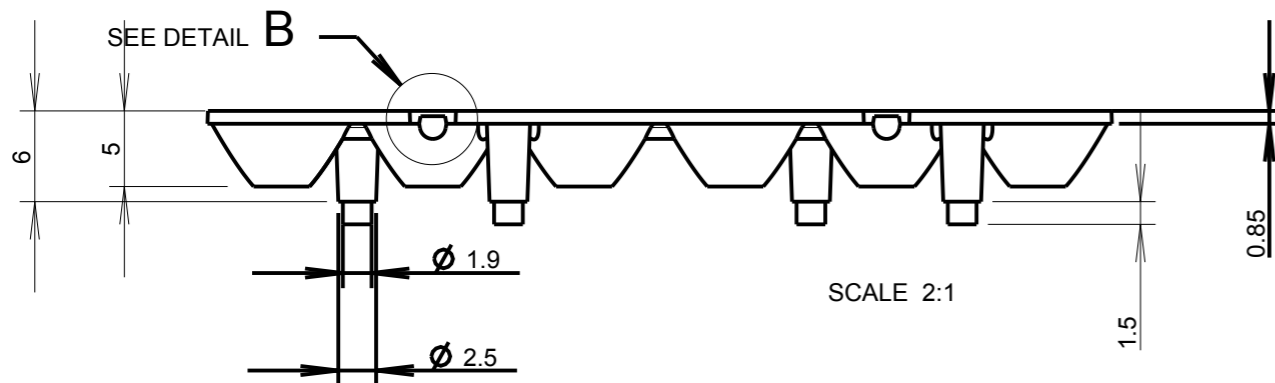
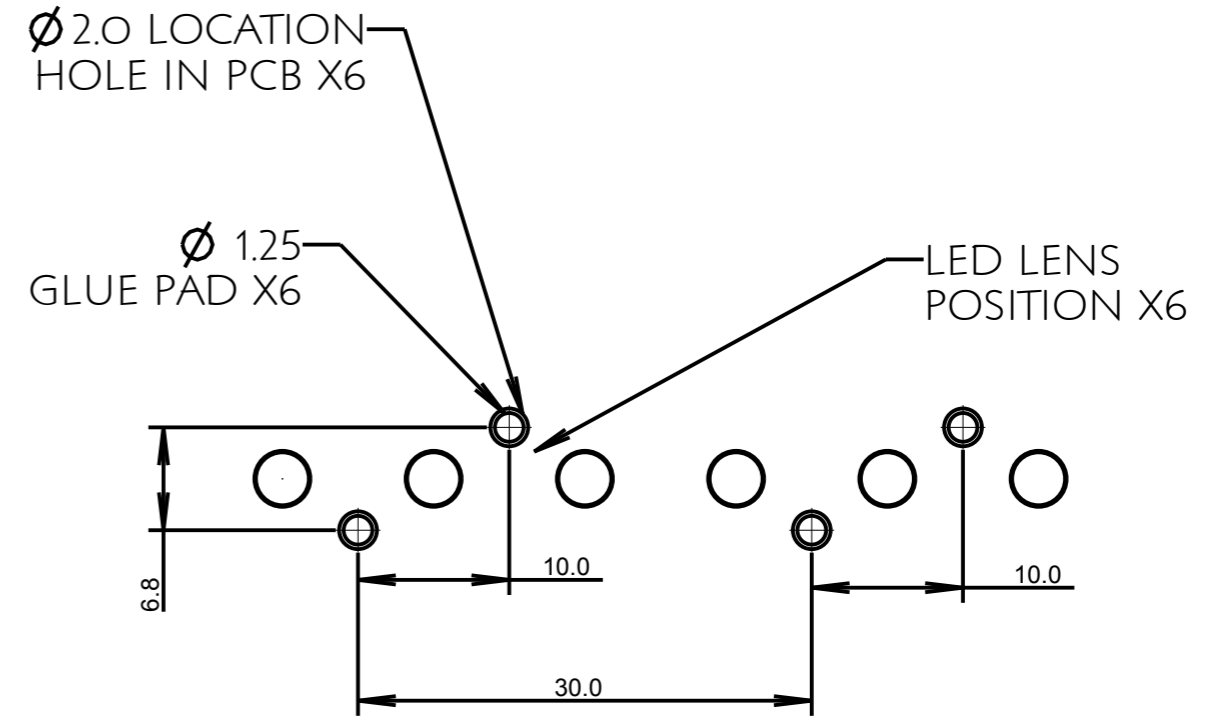
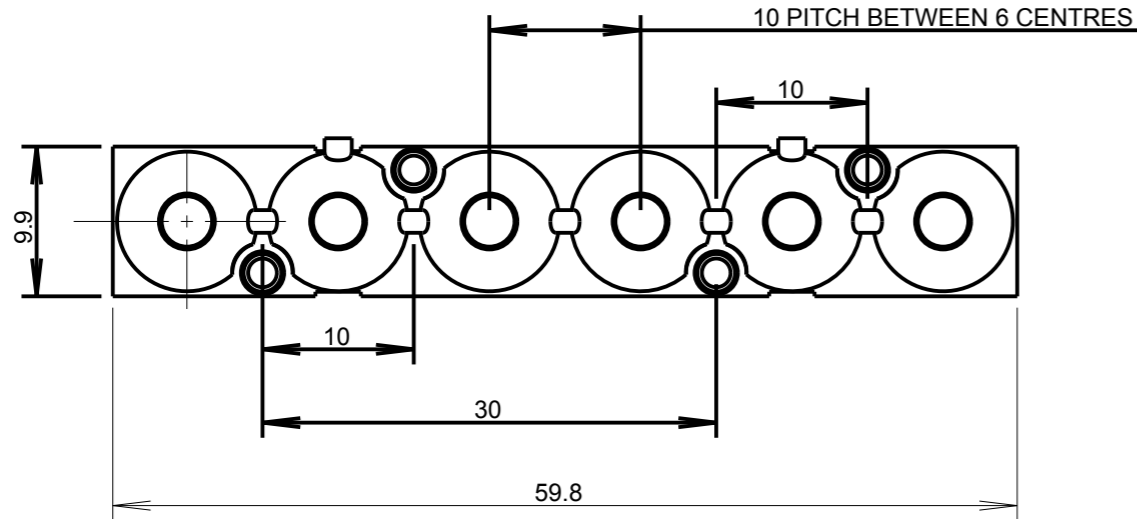

3D GENERAL VIEW
SCALE 1:1

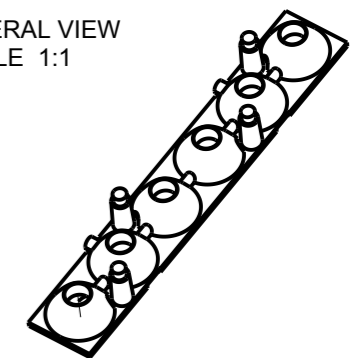

NOTES:

1 - MATERIAL: POLYCARBONATE

2 - FINISH:
OPTICAL SURFACES ARE OPTICALLY POLISHED
COMMERCIAL POLISH FOR ALL NON OPTICAL SURFACES.

3 - GENERAL DRAFT 2°

 CARCLO OPTICS 103 BUCKINGHAM AVE, SLOUGH SL1 4PF, ENGLAND TEL: +44 1753 575011 FAX: +44 1753 811359 email: sales@carclo-optics.com	Title		10mm SPOT LENS 6*1 ARRAY		
	Drawn by	BB	Customer	CARCLO	Scale
THIRD ANGLE PROJECTION	GENERAL TOLERANCES UNLESS OTHERWISE STATED		CARCLO technical plastics		DIMENSIONS IN mm
	0 ±0.25	0 ±0.1	CONFIDENTIAL: UNAUTHORISED COPYING, DISCUSSION & DISTRIBUTION PROHIBITED		Format Size
	0.0 ±0.1	0.0 ±0.05			A3
	0.0 ±0.05	0.0 ±0.1	CAD File	60554	
			Drw. N°	60554	Part N° 10604