

CT815x

Integrated Omnipolar TMR Analog Sensor

Features

- Sensitivity and Magnetic Field Range:
 - $S = 50 \text{ mV/V/mT}$, $B_{ANA} = \pm 8.0 \text{ mT}$
- Analog Output Mode Current Consumption is $\sim 1.3 \mu\text{A}$
 - Current Consumption in Digital Output Only: $\sim 150 \text{ nA}$ @ $V_{DD} = 1.8 \text{ V}$ and $f_s = 12.5 \text{ Hz}$
- Supply Voltage Range: 1.7 V to 5.5 V
- Sensor Polarity: Omnipolar
- Sample and Hold Analog Output @ $f_s = 100 \text{ Hz}$
- Dual Analog and Digital Output Operation Capability
 - Digital Output is Push-pull
- Under-Voltage Lockout (UVLO)
- Package Options:
 - 3-Lead SOT23
 - 5-lead SOT23
 - 4-lead LGA, $1.45 \times 1.45 \times 0.45 \text{ mm}$

Applications

- IoT Devices
- Smartphones, Tablets and Laptops
- Door or Lid Closure
- Tamper-proofing for Utility Smart Meters
- Fluid Level Sensing/Detection
- Proximity Detection
- Motor Controllers
- Gimbals for Camera Systems in Drones/UAVs
- Industrial Machinery/Robots
- Medical Devices

Product Description

The CT815x series of Tunnel Magnetoresistance (TMR) analog sensors (with option for digital latch output) are designed for consumer and industrial applications. It is based on Crocus Technology's patented XtremeSense® TMR technology with integrated CMOS process to provide a monolithic solution for superior sensing performance. Also, the CT815x analog sensors offer magnetic operation over temperature.

The CT815x is an analog sensor product family that provides a linear sample and hold (S&H) analog output voltage with a sampling frequency of 100 Hz.

CT8152 is a TMR sensor that combines both analog and digital outputs in a single chip. It uses the digital output to turn on the analog output so that it can remain in an ultra-low power state until the analog mode is enabled. When the BRP is triggered in digital mode, the analog output function will start operating.

This product family has very low power consumption as low as $1.3 \mu\text{A}$ in analog output mode and 150 nA in digital output mode which makes it ideal for battery-operated products where minimal current consumption is required.

For applications that require a very small form factor and low profile, the CT815x sensors are assembled in a 4-lead LGA package. The CT8150 is also available in an industry standard 3-lead SOT-23 package while CT8152 is offered in a 5-lead SOT23 package to support high volume manufacturing.

Ordering Information

Part Number	Operating Temperature Range	Sensor Type	Analog Output	Digital Output (B _{OP} /B _{RP})	S (mV/V/mT)	Range (mT)	Package	Packing Method
CT8150PC-IS3	-40°C to +85°C	Omnipolar	Yes	No	50	±8.0	3-lead SOT23	Tape & Reel
CT8150PC-HS3	-40°C to +125°C							
CT8150PC-IL4	-40°C to +85°C	Omnipolar	Yes	No	50	±8.0	4-lead LGA	Tape & Reel
CT8150PC-HL4	-40°C to +125°C							
CT8152PC-IS5	-40°C to +85°C	Omnipolar	Yes	Yes (6 mT/4 mT)	50	±8.0	5-lead SOT23	Tape & Reel
CT8152PC-HS5	-40°C to +125°C							
CT8152PC-IL4	-40°C to +85°C	Omnipolar	Yes	Yes (6 mT/4 mT)	50	±8.0	4-lead LGA	Tape & Reel
CT8152PC-HL4	-40°C to +125°C							

Block Diagram

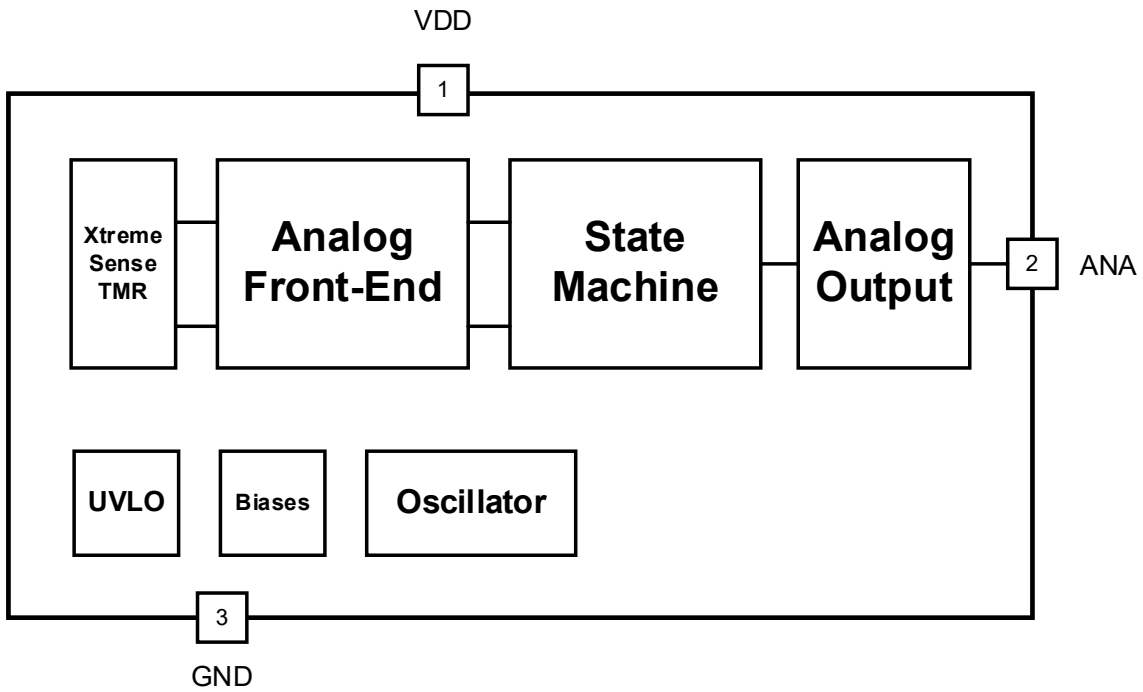

Figure 1. CT8150 with Analog Output Block Diagram

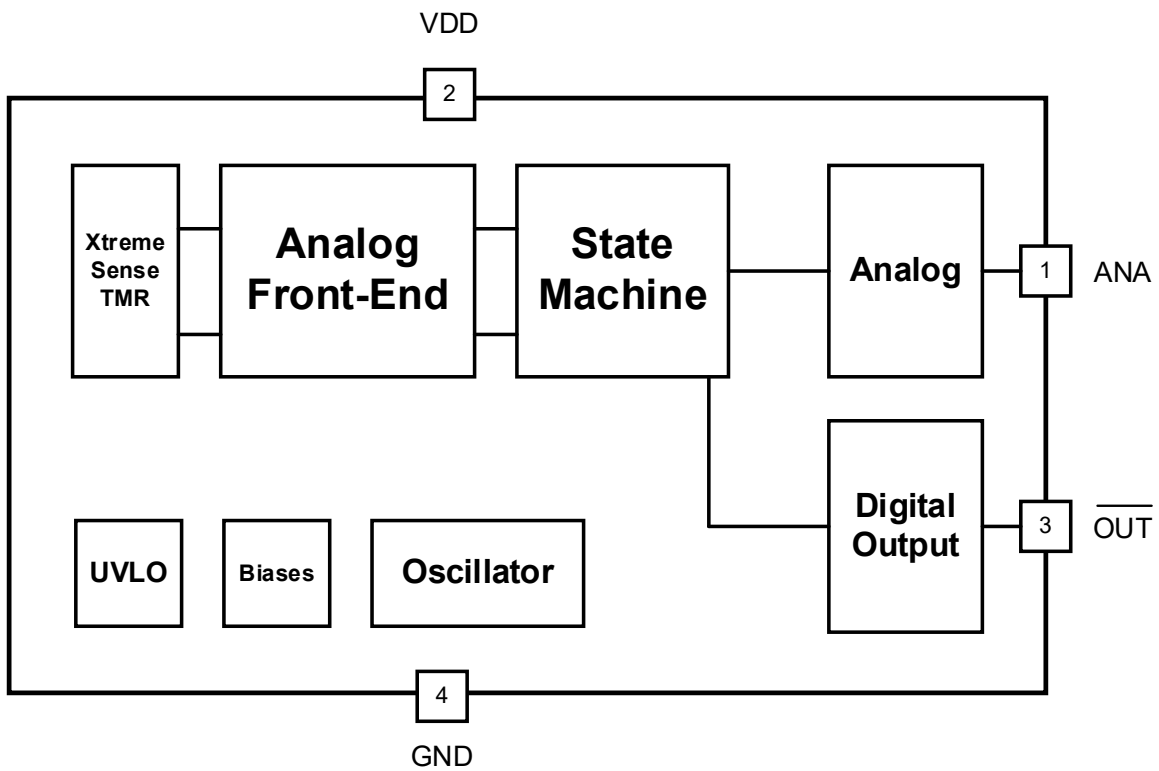

Figure 2. CT8152 with Dual Analog and Digital Outputs Block Diagram

SOT23 Pin Configuration

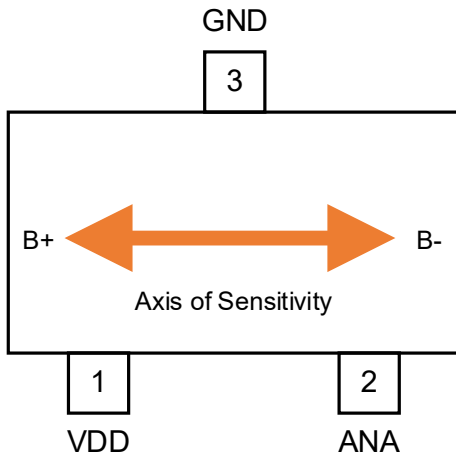

Figure 3. CT8150: 3-Lead SOT23 Package for Analog Output

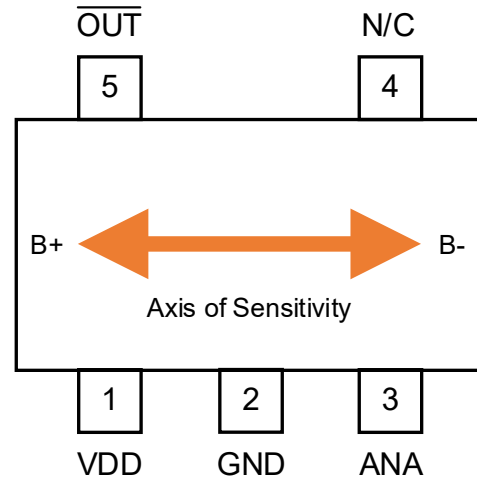

Figure 4. CT8152: 5-Lead SOT23 Package for Analog Output

Pin Definitions

Pin # for CT8150	Pin # of CT8152	Pin Name	Pin Description
1	1	VDD	Supply Voltage
2	2	ANA GND	Analog Output Ground
3	3	GND ANA	Ground Analog Output
-	4	N/C	No Connect
-	5	$\overline{\text{OUT}}$	Output Signal (Active LOW)

LGA Pin Configuration

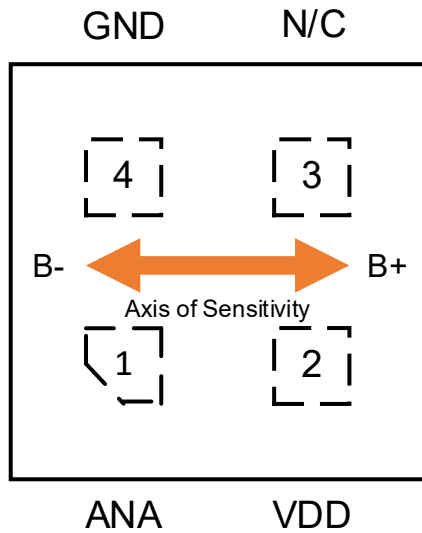

Figure 5. CT8150: 4-Lead LGA Package with Analog Output, Top View

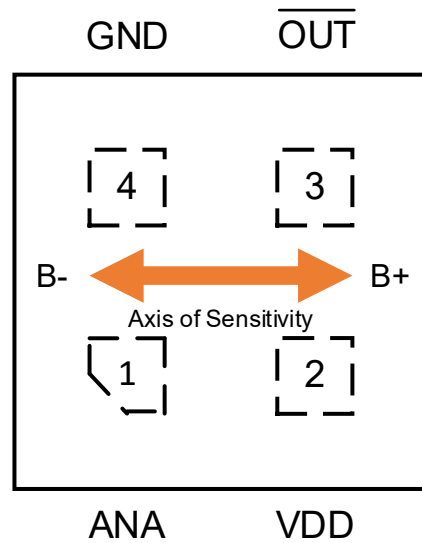

Figure 6. CT8152: 4-Lead LGA Package with Analog and Digital Outputs, Top View

Pin Definitions

Pin #	Pin Name for CT8150	Pin Name for CT8152	Pin Description
1	ANA	ANA	Analog Output
2	VDD	VDD	Supply Voltage
3	N/C	$\overline{\text{OUT}}$	No Connect Output Signal (Active LOW)
4	GND	GND	Ground

Absolute Maximum Ratings

Stresses exceeding the absolute maximum ratings may damage the CT815x. The CT815x products may not function or be operable above the recommended operating conditions and stressing the parts to these levels is not recommended. In addition, extended exposure to stresses above the recommended operating conditions may affect device reliability. The absolute maximum ratings are stress ratings only.

Symbol	Parameter	Min.	Max.	Unit
V _{DD}	Supply Voltage	-0.3	6.0	V
V _{OUT_PP}	Push-pull Output (Active LOW)	-0.3	V _{DD} + 0.3*	V
V _{I/O}	Input/Output Pins Maximum Voltage	-0.3	V _{DD} + 0.3*	V
I _{IN} / I _{OUT}	Input and Output Current		±20.0	mA
B _{MAX}	Maximum External Magnetic Field @ T _A = +25°C		±200	mT
ESD	Electrostatic Discharge Protection Level	Human Body Model (HBM) per JESD22-A114	±4.0	kV
		Charged Device Model (CDM) per JESD22-C101	±0.5	
T _J	Junction Temperature	-40	+150	°C
T _{STG}	Storage Temperature	-65	+150	°C
T _L	Lead Soldering Temperature, 10 Seconds		+260	°C

*The lower of V_{DD} + 0.3 V or 6.0 V.

Recommended Operating Conditions

The Recommended Operating Conditions table defines the conditions for actual operation of the CT815x. Recommended operating conditions are specified to ensure optimal performance to the specifications. Crocus Technology does not recommend exceeding them or designing to absolute maximum ratings.

Symbol	Parameter	Min.	Typ.	Max.	Unit	
V _{DD}	Supply Voltage Range	1.7	3.3	5.5	V	
V _{OUT}	OUT Voltage Range	0		V _{DD}	V	
B _{OP}	Operating Magnetic Flux			30	mT	
I _{OUT}	OUT Current			±3.0	mA	
C _{BYP}	Bypass Capacitor		1.0		µF	
T _A	Operating Ambient Temperature	Industrial	-40	+25	+85	°C
		Extended Industrial	-40	+25	+125	
T _J	Operating Junction Temperature	-40		+125	°C	

Thermal Properties

Junction-to-ambient thermal resistance is a function of application and board layout and is determined in accordance to JEDEC standard JESD51 for a four (4) layer 2s2p FR-4 printed circuit board (PCB) with 2 oz. of copper (Cu). Special attention must be paid to not exceed junction temperature T_{J(MAX)} at a given ambient temperature T_A.

Symbol	Parameter	Min.	Typ.	Max.	Unit
θ _{JA}	Junction-to-Ambient Thermal Resistance, SOT23-3		202		°C/W
θ _{JA}	Junction-to-Ambient Thermal Resistance, LGA-4		165		°C/W

Electrical Specifications

General Parameters

Unless otherwise specified: $V_{DD} = 1.7 \text{ V to } 5.5 \text{ V}$, $C_{BYP} = 1.0 \mu\text{F}$ and $T_A = -40^\circ\text{C to } +125^\circ\text{C}$. Typical values are $V_{DD} = 3.3 \text{ V}$ and $T_A = +25^\circ\text{C}$.

Symbol	Parameter	Conditions	Min.	Typ.	Max.	Unit
Timings						
t_{ON}	Power-On Time ⁽¹⁾	$V_{DD} \geq 1.7 \text{ V}$		50	75	μs
t_{ACTIVE}	Active Mode Time ⁽¹⁾			2.6		μs
Protection						
V_{UVLO}	Under-Voltage Lockout ⁽¹⁾	Rising V_{DD}		1.60	1.64	V
		Falling V_{DD}	1.44	1.53		V
V_{UV_HYS}	UVLO Hysteresis ⁽¹⁾			70		mV

(1) Guaranteed by design and characterization; not tested in production.

Typical Timing Characteristics

$V_{DD} = 3.3 \text{ V}$, $T_A = +25^\circ\text{C}$ and $C_{BYP} = 1.0 \mu\text{F}$ (unless otherwise specified)

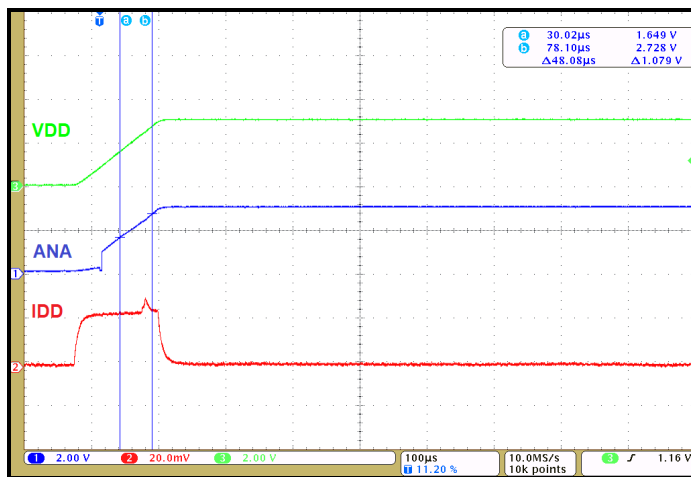

Figure 7. Power-On Time for Analog Output

CT8150PC Electrical & Magnetic Specifications

Unless otherwise specified: $V_{DD} = 1.7\text{ V to }5.5\text{ V}$, $C_{BYP} = 1.0\ \mu\text{F}$ and $T_A = -40^\circ\text{C to }+125^\circ\text{C}$. Typical values are $V_{DD} = 3.3\text{ V}$ and $T_A = +25^\circ\text{C}$.

Symbol	Parameter	Conditions	Min.	Typ.	Max.	Unit
$I_{DD(AVG)}$	Average Supply Current	$t \geq 10\text{ s}$		1.5	5.0	μA
$I_{DD(AVG)_1.8V}$	Average Supply Current @ $V_{DD} = 1.8\text{ V}$	$t \geq 10\text{ s}, V_{DD} = 1.8\text{ V}$		1.3	3.0	μA
f_s	Sampling Frequency		60	100	140	Hz
t_{DLE}	Idle Mode Time	$f_s = 100\text{ Hz}$	7.1	10.0	16.7	ms
$I_{DRV(MAX)}$	Maximum Drive Capability ⁽¹⁾	$\Delta V_{OUT} \leq 10\text{ mV}$	-10		+10	μA
C_L	Output Capacitive Load ⁽¹⁾				10	pF
B_{ANA}	Analog Output Magnetic Field		± 5.4	± 8.0	± 10.0	mT
V_{ANA}	Analog Output Voltage Range		$0.1 \times V_{DD}$		$0.9 \times V_{DD}$	V
V_{OQ}	Voltage Output Quiescent		45	50	55	% V_{DD}
S	Sensitivity		35	50	65	mV/V/mT

(1) Guaranteed by design and characterization; not tested in production.

Typical Magnetic Characteristics for CT8150PC

$V_{DD} = 3.3\text{ V}$, $T_A = +25^\circ\text{C}$ and $C_{BYP} = 1.0\ \mu\text{F}$ (unless otherwise specified)

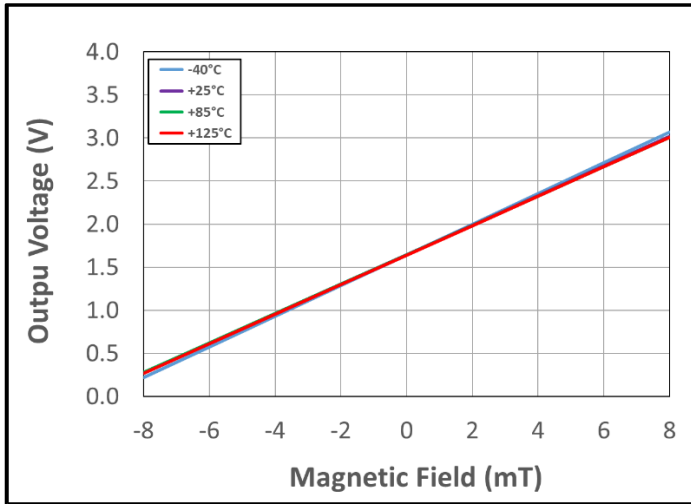

Figure 8. Output Voltage vs. Magnetic Field over Temperature at $V_{DD} = 3.3\text{ V}$.

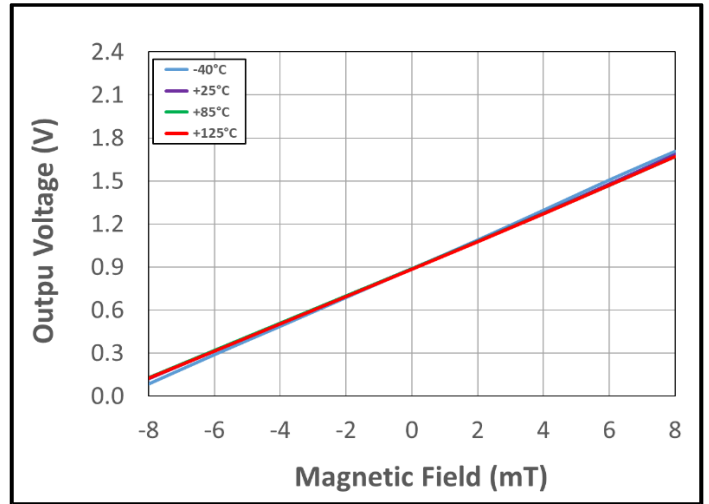

Figure 9. Output Voltage vs. Magnetic Field over Temperature at $V_{DD} = 1.8\text{ V}$.

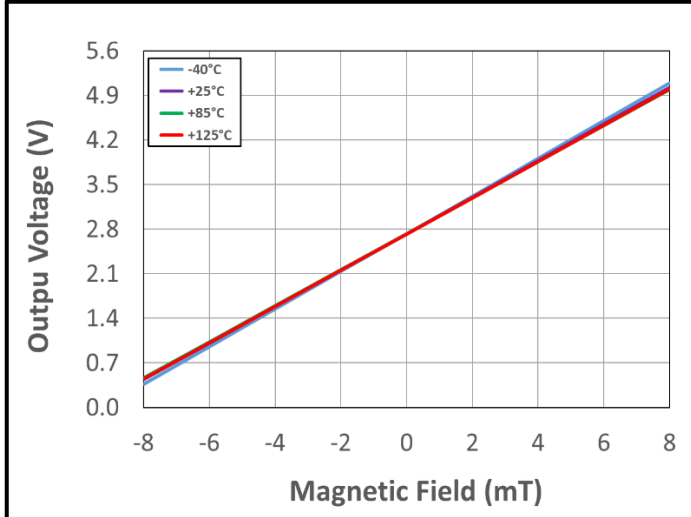

Figure 10. Output Voltage vs. Magnetic Field over Temperature at $V_{DD} = 5.5\text{ V}$.

Typical Electrical Characteristics for CT8150PC

$V_{DD} = 3.3\text{ V}$, $T_A = +25^\circ\text{C}$ and $C_{BYP} = 1.0\ \mu\text{F}$ (unless otherwise specified)

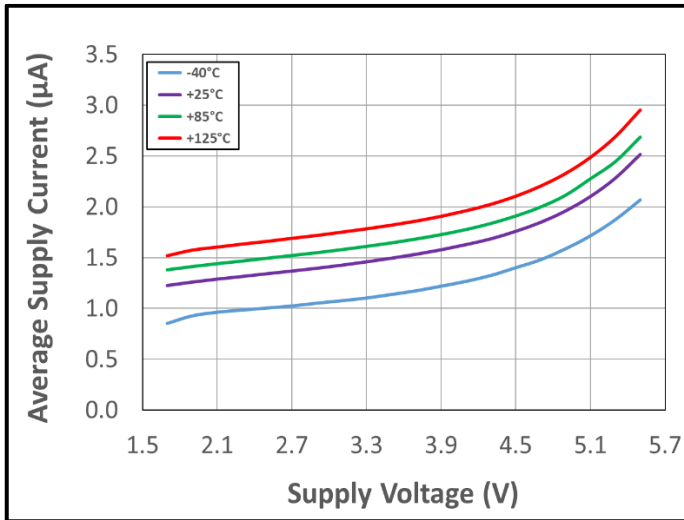

Figure 11. Average Supply Current vs. Supply Voltage vs. Temperature

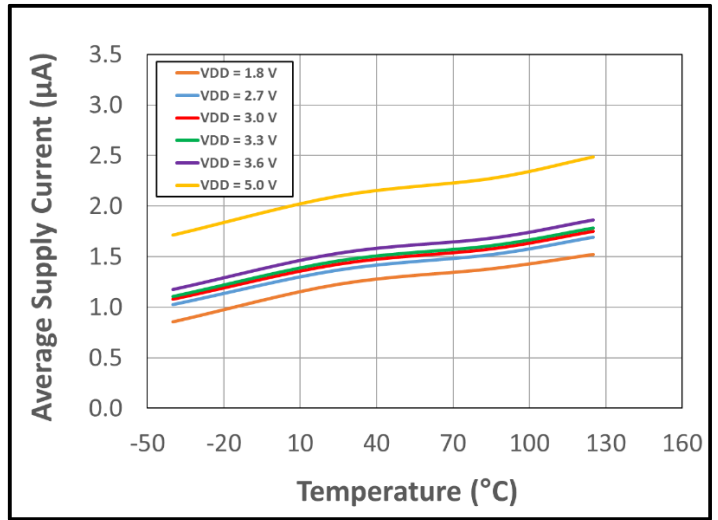

Figure 12. Average Supply Current vs. Temperature vs. Supply Voltage

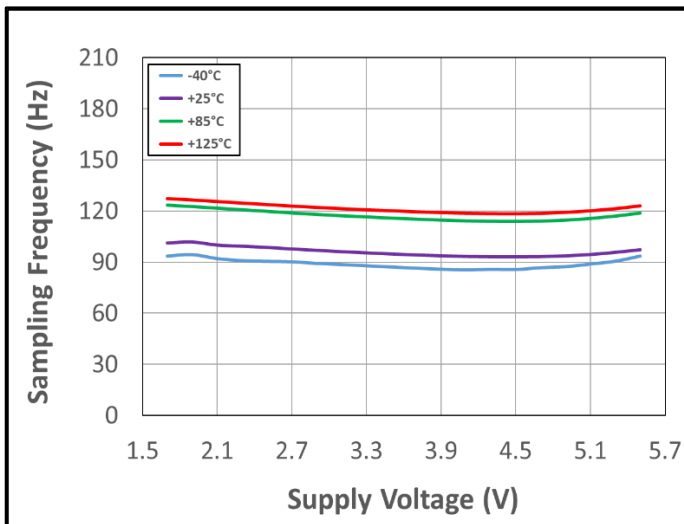

Figure 13. Sampling Frequency vs. Supply Voltage vs. Temperature

CT8152PC Electrical & Magnetic Specifications

Unless otherwise specified: $V_{DD} = 1.7\text{ V to }5.5\text{ V}$, $C_{BYP} = 1.0\ \mu\text{F}$ and $T_A = -40^\circ\text{C to }+125^\circ\text{C}$. Typical values are $V_{DD} = 3.3\text{ V}$ and $T_A = +25^\circ\text{C}$.

Symbol	Parameter	Conditions	Min.	Typ.	Max.	Unit
Analog Output Mode (Digital Mode is ON)						
$I_{DD(AVG)}$	Average Supply Current	$t \geq 10\text{ s}$, Analog and Digital Modes ON		1.5	5.0	μA
$I_{DD(AVG)_1.8V}$	Average Supply Current @ $V_{DD} = 1.8\text{ V}$	$t \geq 10\text{ s}$, $V_{DD} = 1.8\text{ V}$, Analog and Digital Modes ON		1.3	3.0	μA
$I_{DRV(MAX)}$	Maximum Drive Capability (1)	$\Delta V_{OUT} \leq 10\text{ mV}$	-10		+10	μA
f_{S_ANA}	Analog Sampling Frequency		60	100	140	Hz
t_{IDLE_ANA}	Idle Mode Time, Analog Output	$f_s = 100\text{ Hz}$	7.1	10.0	16.7	ms
C_L	Output Capacitive Load (1)				10	pF
B_{ANA}	Analog Output Magnetic Field		± 5.4	± 8.0	± 10.0	mT
V_{ANA}	Analog Output Voltage Range		$0.1 \times V_{DD}$		$0.9 \times V_{DD}$	V
V_{OQ}	Voltage Output Quiescent		45	50	55	% V_{DD}
S	Sensitivity		35	50	65	mV/V/mT
Digital Output Mode						
$I_{DD(AVG)}$	Average Supply Current	$t \geq 10\text{ s}$, Analog Mode OFF		200	900	nA
$I_{DD(AVG)_1.8V}$	Average Supply Current @ $V_{DD} = 1.8\text{ V}$	$t \geq 10\text{ s}$, $V_{DD} = 1.8\text{ V}$, Analog Mode OFF		150	700	nA
V_{OH}	Output Voltage High \overline{OUT} (1)		$0.9 \times V_{DD}$			V
V_{OL}	Output Voltage LOW \overline{OUT} (1)				$0.1 \times V_{DD}$	V
I_{OUT}	Current for \overline{OUT} (1)			± 2.0		mA
f_{S_DIG}	Digital Sampling Frequency		7.5	12.5	17.5	Hz
t_{IDLE_DIG}	Idle Mode Time, Digital Output	$f_s = 10\text{ Hz}$	57	80	133	ms
B_{OPN}	Operate Point, B-		4.6	6.0	7.6	mT
B_{OPS}	Operate Point, B+		-7.6	-6.0	-4.6	mT
B_{RPN}	Release Point, B-		2.8	4.0	5.6	mT
B_{RPS}	Release Point, B+		-5.6	-4.0	-2.8	mT
B_{HYST}	Hysteresis		1.0	2.0		mT

(1) Guaranteed by design and characterization; not tested in production.

Typical Magnetic Characteristics for CT8152PC in Digital Mode

$V_{DD} = 3.3\text{ V}$, $T_A = +25^\circ\text{C}$ and $C_{BYP} = 1.0\ \mu\text{F}$ (unless otherwise specified)

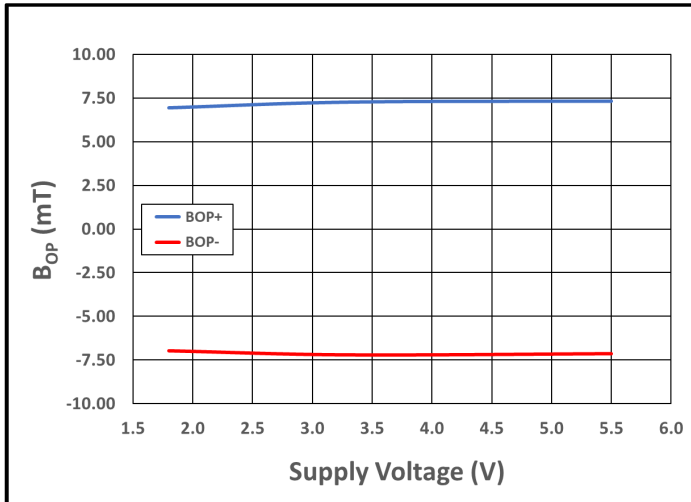

Figure 14. B_{OP} . (Red) and B_{OP+} (Blue) vs. Supply Voltage at $T_A = +25^\circ\text{C}$

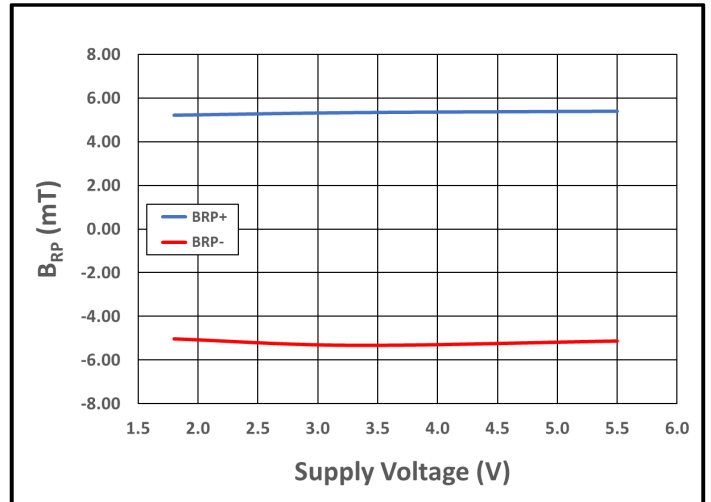

Figure 15. B_{RP} . (Red) and B_{RP+} (Blue) vs. Supply Voltage at $T_A = +25^\circ\text{C}$

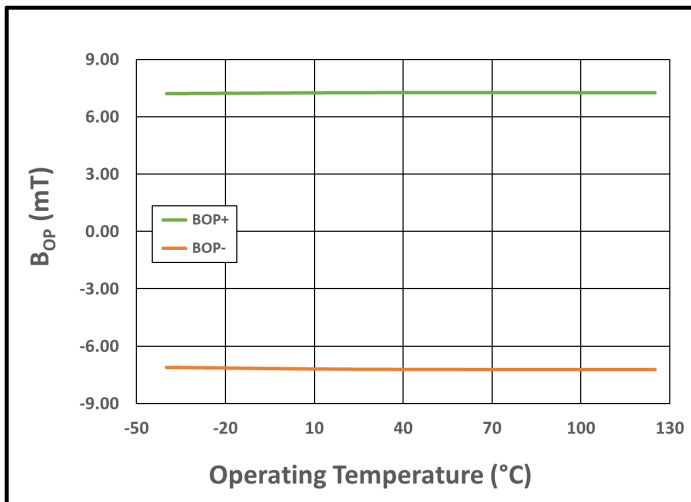

Figure 16. B_{OP} . (Orange) and B_{OP+} (Green) vs. Temperature at $V_{DD} = 3.3\text{ V}$

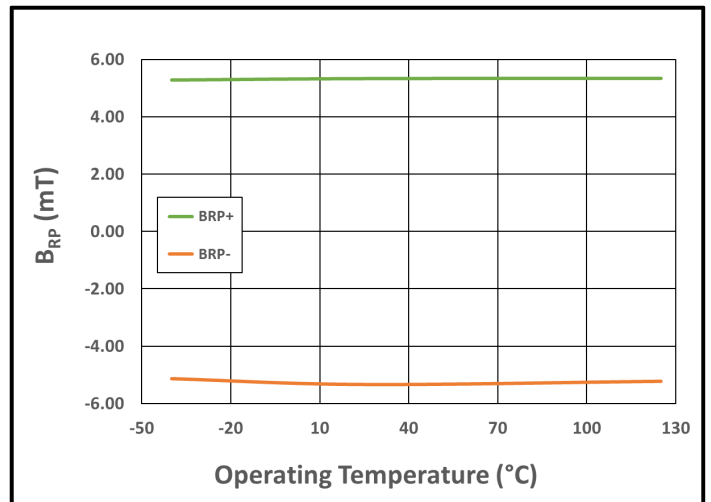

Figure 17. B_{RP} . (Orange) and B_{RP+} (Green) vs. Temperature at $V_{DD} = 3.3\text{ V}$

Typical Magnetic Characteristics for CT8152PC in Analog Mode

$V_{DD} = 3.3\text{ V}$, $T_A = +25^\circ\text{C}$ and $C_{BYP} = 1.0\ \mu\text{F}$ (unless otherwise specified)

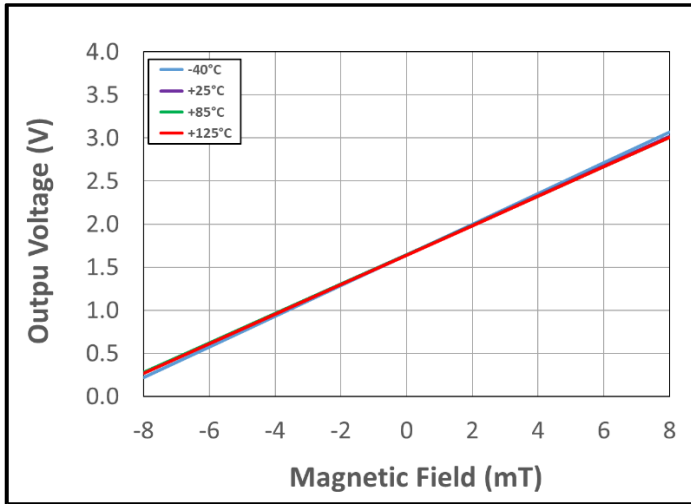

Figure 18. Output Voltage vs. Magnetic Field over Temperature at $V_{DD} = 3.3\text{ V}$.

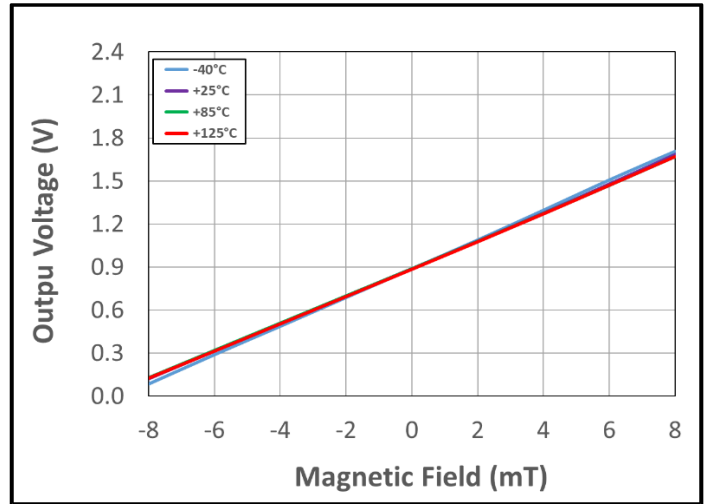

Figure 19. Output Voltage vs. Magnetic Field over Temperature at $V_{DD} = 1.8\text{ V}$.

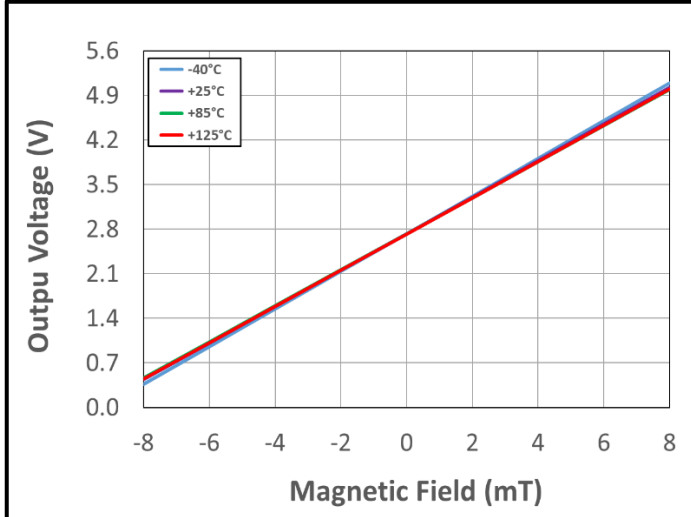

Figure 20. Output Voltage vs. Magnetic Field over Temperature at $V_{DD} = 5.5\text{ V}$.

Typical Electrical Characteristics for CT8152PC in Digital Mode Only

$V_{DD} = 3.3\text{ V}$, $T_A = +25^\circ\text{C}$ and $C_{BYP} = 1.0\ \mu\text{F}$ (unless otherwise specified)

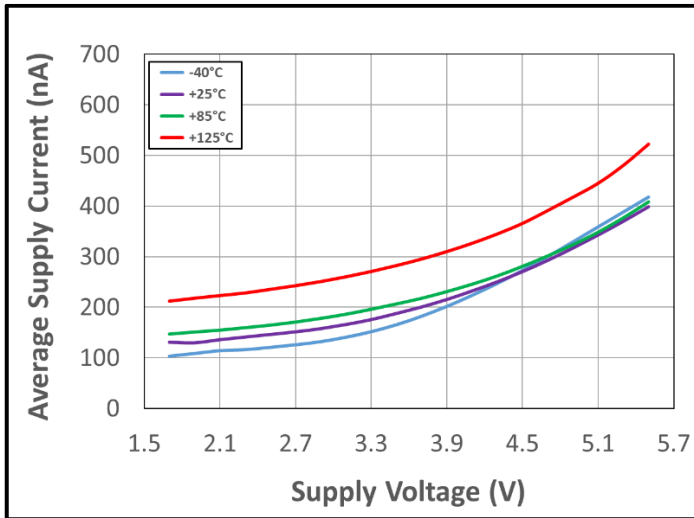

Figure 21. Average Supply Current vs. Supply Voltage vs. Temperature

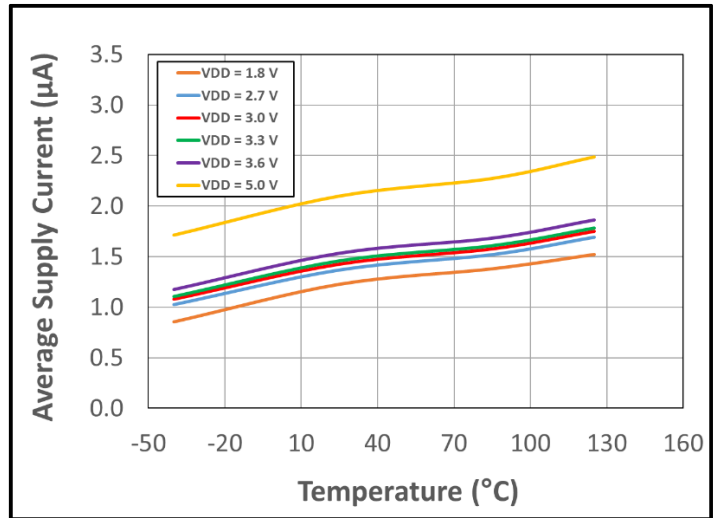

Figure 22. Average Supply Current vs. Temperature vs. Supply Voltage

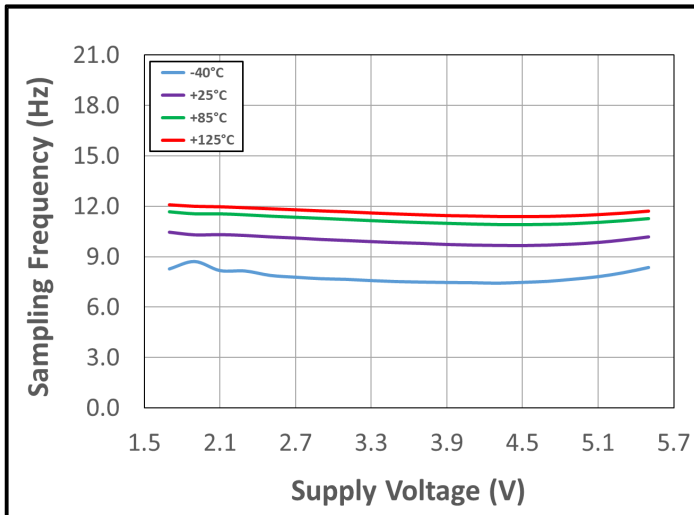

Figure 23. Sampling Frequency vs. Supply Voltage vs. Temperature

Typical Electrical Characteristics for CT8152PC in Analog & Digital Mode

$V_{DD} = 3.3\text{ V}$, $T_A = +25^\circ\text{C}$ and $C_{BYP} = 1.0\ \mu\text{F}$ (unless otherwise specified)

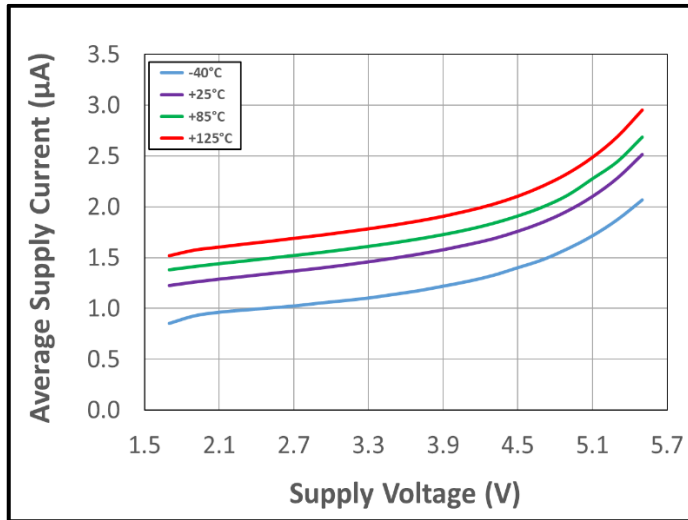

Figure 24. Average Supply Current vs. Supply Voltage vs. Temperature

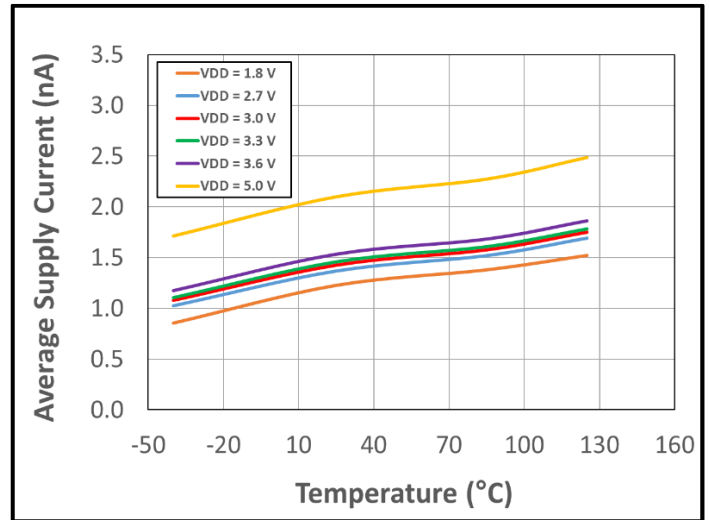

Figure 25. Average Supply Current vs. Temperature vs. Supply Voltage

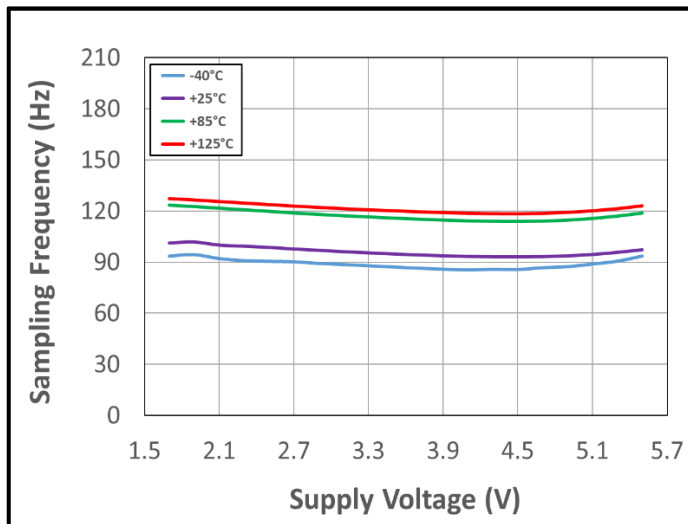

Figure 26. Sampling Frequency vs. Supply Voltage vs. Temperature

Circuit Description

Overview

The CT815x is a product family of TMR analog sensors that provides a linear analog output voltage for a range of magnetic fields. It supports a wide operating voltage range of 1.7 V to 5.5 V enabling it to be used in many applications. Designed to consume a minimal amount of current which is ideal for battery-powered products.

Analog Output Measurement

The CT815x provides a continuous (sample & hold) linear analog output voltage which represents the measured magnetic field. The output voltage range of ANA is 10% of V_{DD} to 90% of V_{DD} which represents the magnetic field from the typical low-end value of -8.0 mT to the maximum magnetic field value of +8.0 mT for a sensitivity of 50 mV/V/mT. A resistor-capacitor (R-C) filter may be implemented on the ANA pin to further lower the noise. Figure 27 illustrates the output voltage range of the ANA pin as a function of the measured current.

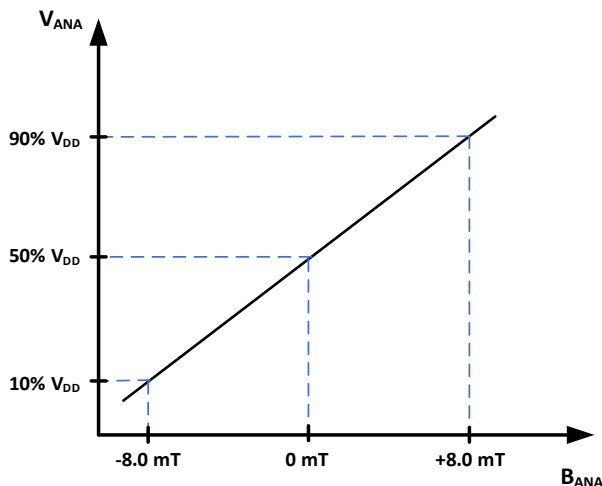

Figure 27. Linear Output Voltage Range vs. Measured Magnetic Field for $S = 50$ mV/V/mT.

Dual Analog & Digital Output Mode

The CT8152 supports both a digital and an analog signal output operating at the same time. The analog output will turn ON when the B_{RP} on the digital output side is triggered at ± 8.0 mT and both outputs remain on until the CT8152 is powered OFF. The digital output is configured as a CMOS push-pull and it will start sampling one full cycle/period once dual output mode has been initiated. The analog and digital outputs have a sampling frequency of 80 Hz and 10 Hz respectively and they work independently of one another.

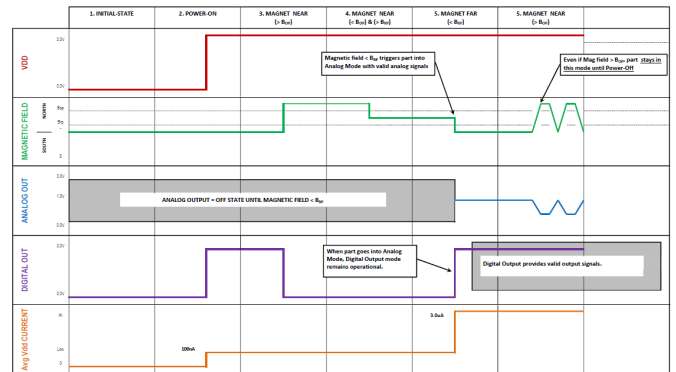

Figure 28. Dual Analog and Digital Mode Operating Conditions of the CT8152.

Under-Voltage Lockout (UVLO)

The Under-Voltage Lock-out protection circuitry of the CT815x is activated when the supply voltage (V_{DD}) falls below 1.53 V. The CT815x remains in a low quiescent state and the ANA and \overline{OUT} outputs are not valid until V_{DD} rises above the UVLO threshold (1.60 V).

Power-On Time (t_{ON})

The Power-On Time (t_{ON}) of 50 μ s is the amount of time required by the CT815x to start up, power-on and acquire the first sample. The chip is fully powered up and operational from the moment the supply voltage passes the rising UVLO point (1.60 V). This time includes the ramp up time and the settling time (within 10% of steady-state voltage under an applied magnetic field) after the power supply have reach the minimum V_{DD} .

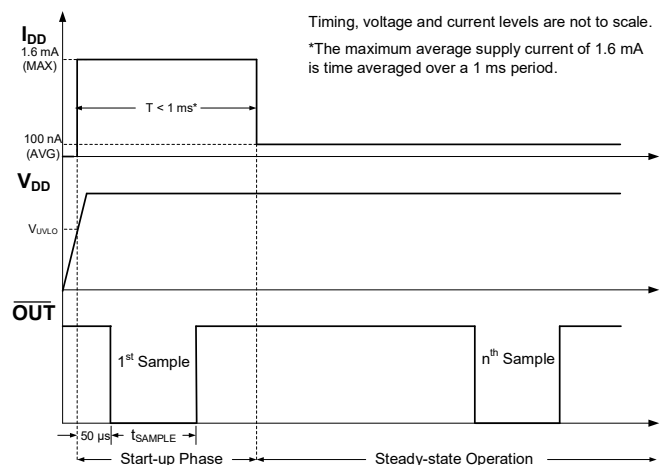

Figure 29. CT815x Power-On Timing Diagram

Applications Information

A decoupling capacitor, C_{BYP} , between the supply voltage (VDD) and ground (GND) is required to lower the noise going into the CT815x products as well as providing isolation from the other circuits. The decoupling capacitor should be placed close to the TMR analog sensor. A typical capacitor value of $1.0 \mu\text{F}$ (ceramic) will be sufficient.

For the analog output, a simple RC filter ($R = 47 \text{ k}\Omega$ and $C = 100 \text{ pF}$) is recommended on the ANA pin as shown in Figure 30.

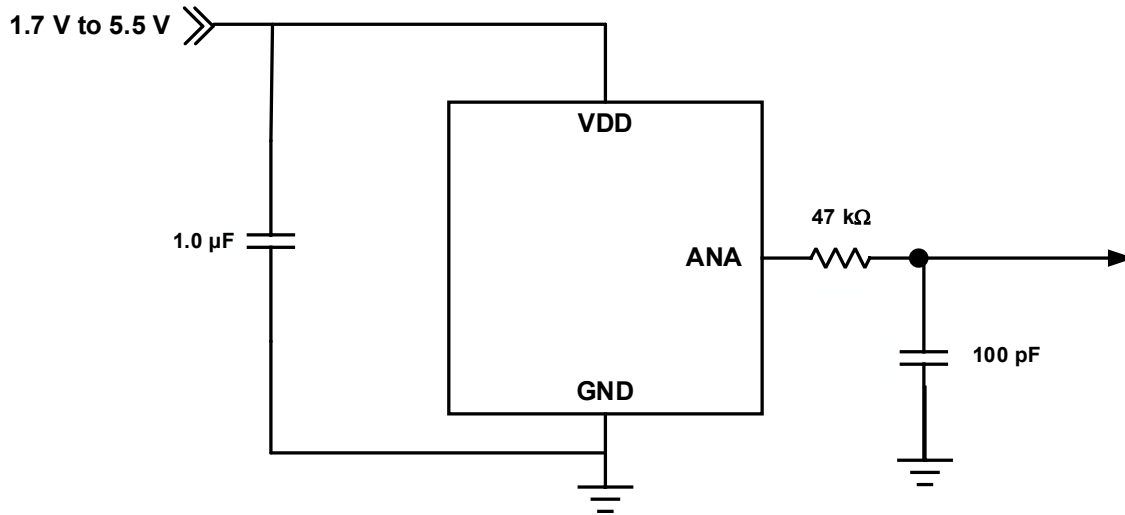

Figure 30. CT8150 Application Block Diagram

For the CT8152, the same bypass capacitor and RF filter of the CT8150 should be implemented.

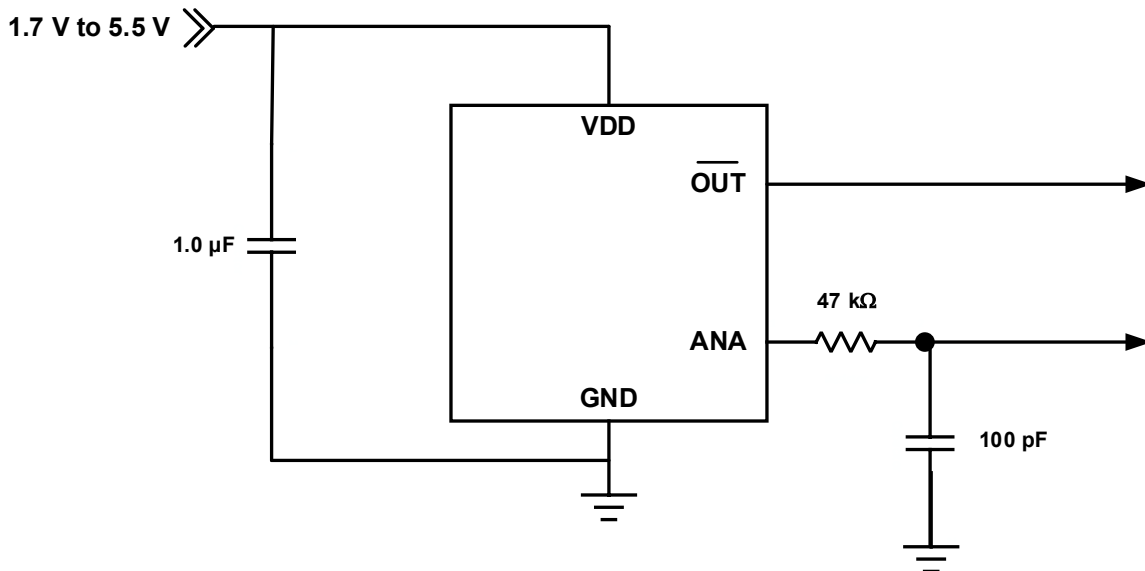

Figure 31. CT8152 Application Block Diagram

Applications Information

The XtremeSense TMR sensor location for the CT815x products are shown in Figure 32, Figure 33 and Figure 34. The dimensions shown in the three figures are typical values.

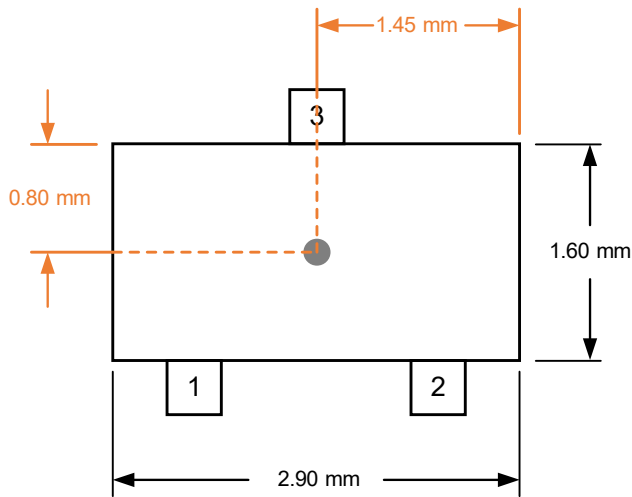

Figure 32. XtremeSense TMR Sensor Location for CT8150 products in 3-lead SOT23 Package

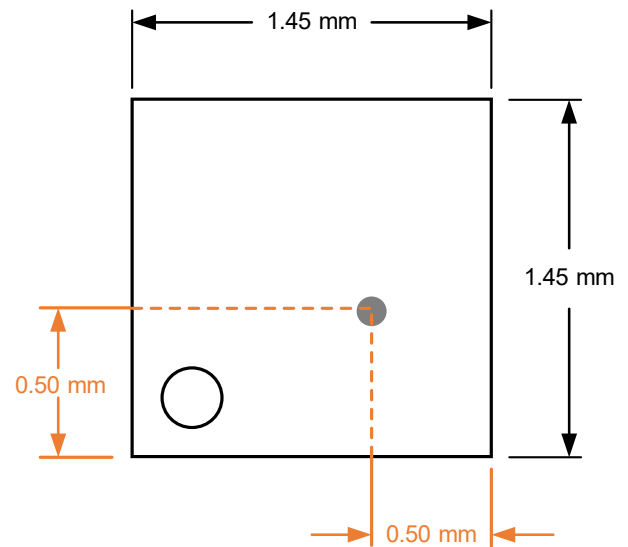

Figure 33. XtremeSense TMR Sensor Location for CT815x products in 4-lead LGA Package

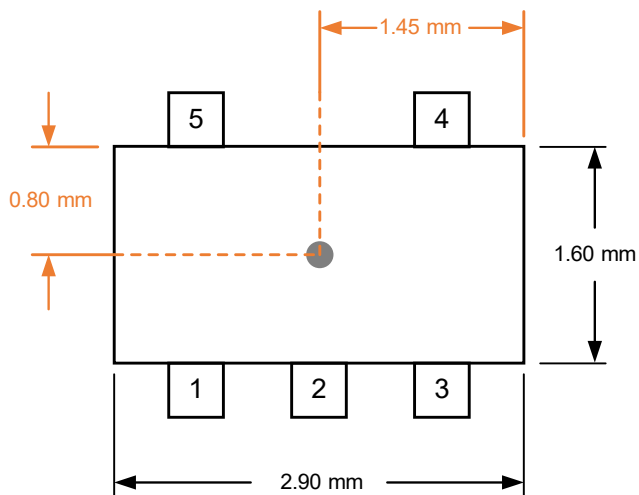

Figure 34. XtremeSense TMR Sensor Location for CT8152 products in 3-lead SOT23 Package

SOT23-3 Package Drawing and Dimensions

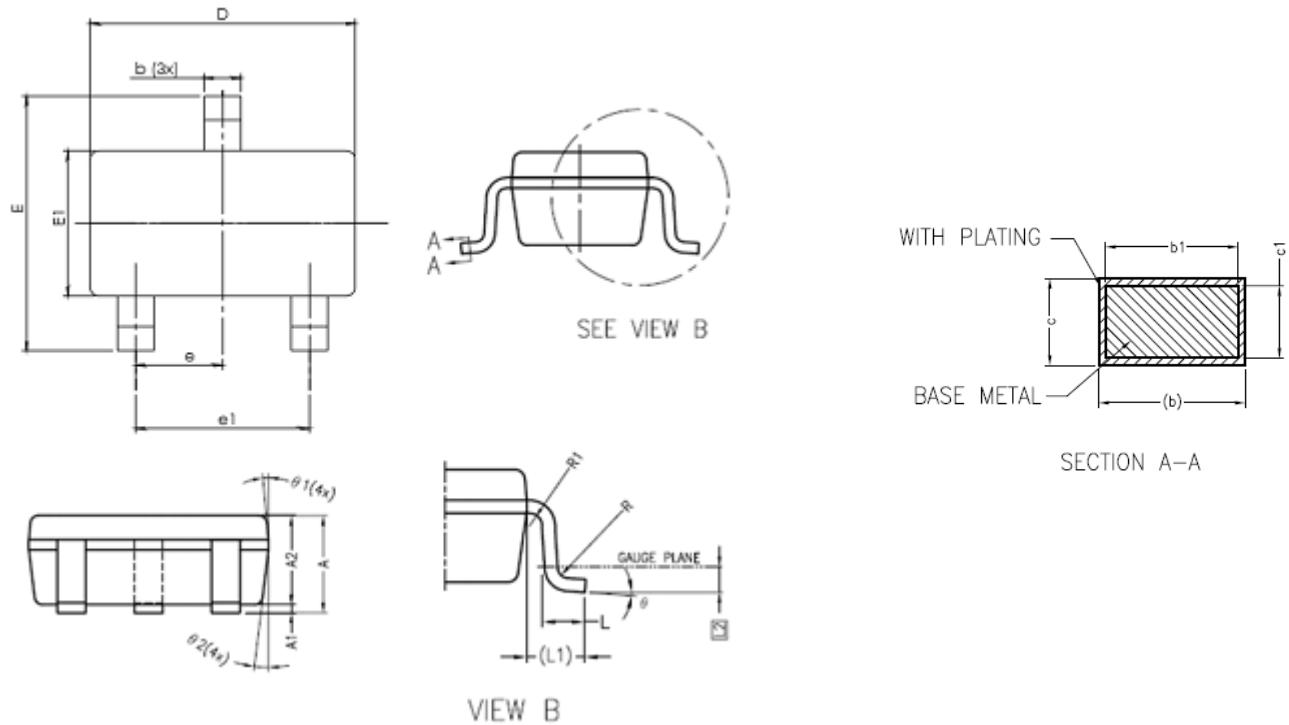

Figure 35. 3-Lead SOT23 Package Drawing

Table 1. CT8150 3-Lead SOT23 Package Dimensions

Symbol	Dimensions in Millimeters (mm)		
	Min.	Typ.	Max.
A	1.05	1.20	1.35
A1	0.00	0.10	0.15
A2	1.00	1.10	1.20
b	0.30	-	0.50
b1	0.30	0.35	0.45
c	0.08	-	0.22
c1	0.08	0.13	0.20
D	2.80	2.90	3.00
E	2.60	2.80	3.00
E1	1.50	1.60	1.70
e	0.95 BSC		
e1	1.90 BSC		
L	0.35	0.43	0.60
L1	0.60 REF		
L2	0.25 BSC		
R	0.10	-	-
R1	0.10	-	0.25
θ	0°	4°	8°
θ1	5°	6°	15°
θ2	5°	8°	15°

Crocus Technology provides package drawings as a service to customers considering or planning to use Crocus products in their designs. Drawings may change without notice. Please note the revision and date of the data sheet and contact a Crocus Technology representative to verify or obtain the most recent version. The package specifications do not expand the terms of Crocus Technology's worldwide terms and conditions, specifically the warranty therein, which covers Crocus Technology's products.

SOT23-3 Tape & Pocket Drawing and Dimensions

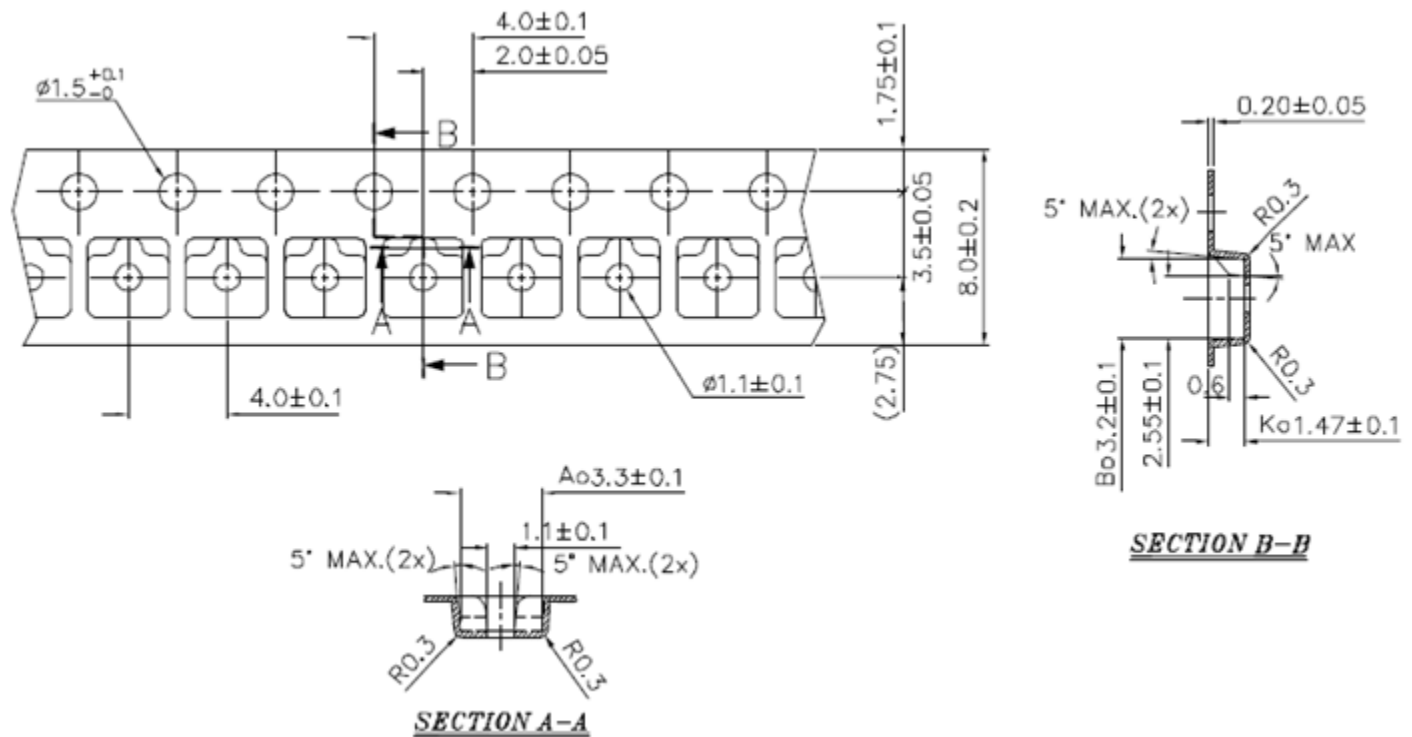

NOTES:

1. Material: Conductive Polystyrene
2. Dimensions in mm.
3. 10 sprocket hole pitch cumulative tolerance ± 0.20 mm.
4. Camber bot to exceed 1 mm in 100 mm.
5. Pocket position relative to sprocket hole measured as true position of pocket and not pocket hole.
6. (S.R. Ω/sq) means surface electric resistivity of the carrier tape.

Figure 36. Tape and Pocket Drawing for 3-lead SOT23 Package

LGA-4 Package Drawing and Dimensions

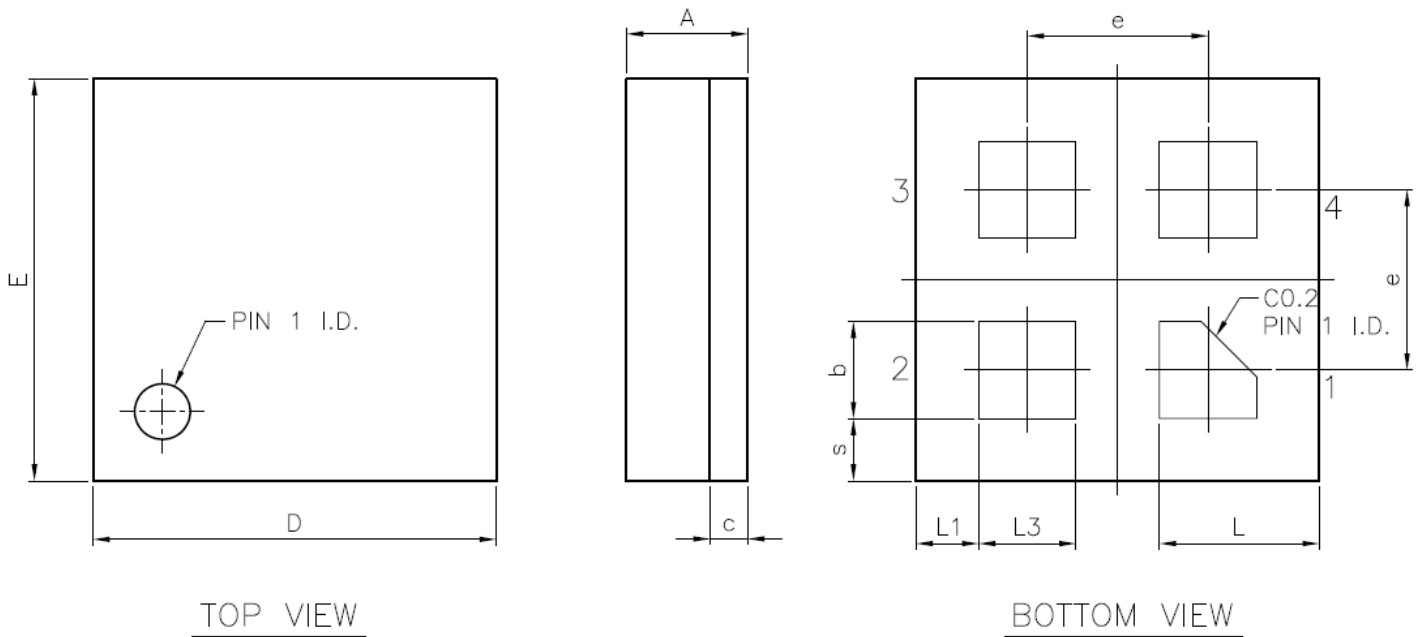

NOTE:

1. All dimensions are in millimeters.
2. Pin A1 ID is marked by ink or laser.

Figure 37. 4-Lead LGA Package Drawing

Table 2. CT815x 4-Lead LGA Package Dimensions

Symbol	Dimensions in Millimeters (mm)		
	Min.	Typ.	Max.
A	0.386	0.436	0.486
b	0.300	0.350	0.400
c	-	0.136 REF	-
D	1.400	1.450	1.500
E	1.400	1.450	1.500
e	-	0.65	-
L	0.525	0.575	0.625
L1	0.175	0.225	0.275
L3	0.300	0.350	0.400
s	0.175	0.225	0.275

Crocus Technology provides package drawings as a service to customers considering or planning to use Crocus products in their designs. Drawings may change without notice. Please note the revision and date of the data sheet and contact a Crocus Technology representative to verify or obtain the most recent version. The package specifications do not expand the terms of Crocus Technology's worldwide terms and conditions, specifically the warranty therein, which covers Crocus Technology's products.

LGA-4 Tape & Pocket Drawing and Dimensions

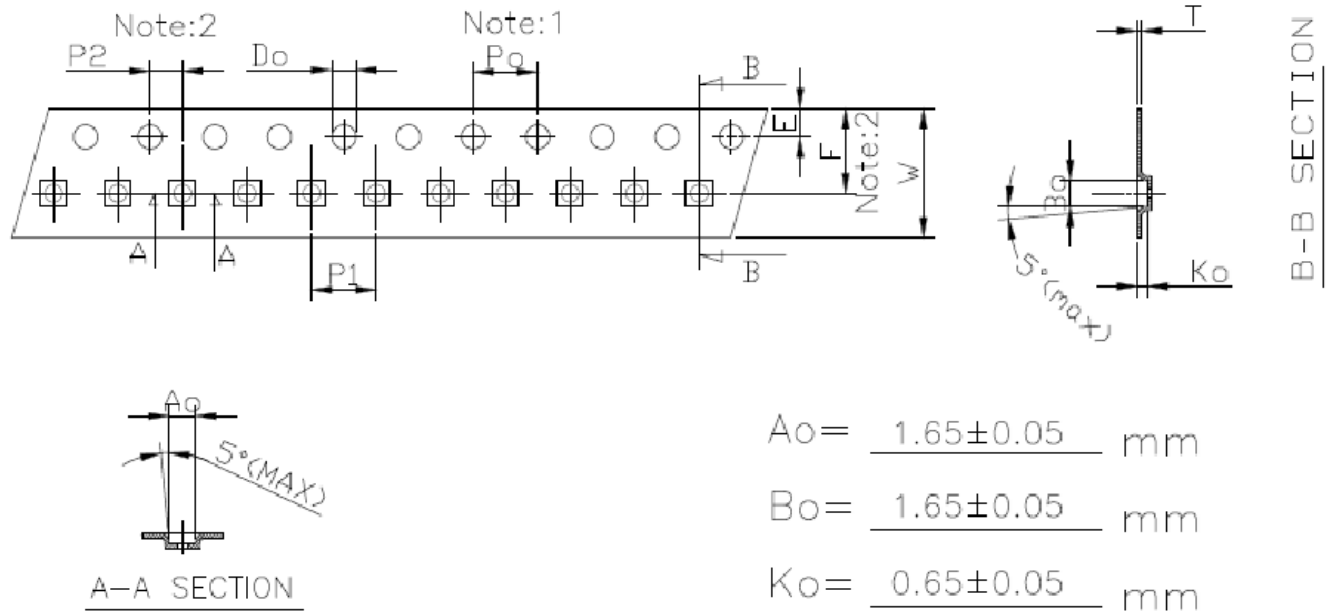

Figure 38. Tape and Pocket Drawing for LGA-4 Package

Table 3. LGA-4 Tape and Pocket Dimensions

Symbol	Specification
P_o	4.00 mm \pm 0.10 mm
P_1	4.00 mm \pm 0.10 mm
P_2	2.00 mm \pm 0.05 mm
D_o	1.50 mm \pm 0.10 mm
D_1	1.10 mm \pm 0.05 mm
E	1.75 mm \pm 0.10 mm
F	3.50 mm \pm 0.05 mm
$10P_o$	40.00 mm \pm 0.10 mm
W	8.00 mm \pm 0.20 mm
T	0.25 mm \pm 0.02 mm

Notes:

- 10 Sprocket hole pitch cumulative tolerance is ± 0.10 mm.
- Pocket position is relative to sprocket hole measured as true position of pocket and not pocket hole.
- A_o and B_o measured on a plane of 0.3 mm above the bottom of the pocket to top surface of the carrier.
- K_o measured from a plane on the inside bottom of the pocket to the top surface of the carrier.
- Carrier camber shall not more than 1 mm per 100 mm through a length of 250 mm.

SOT23-5 Package Drawing and Dimensions

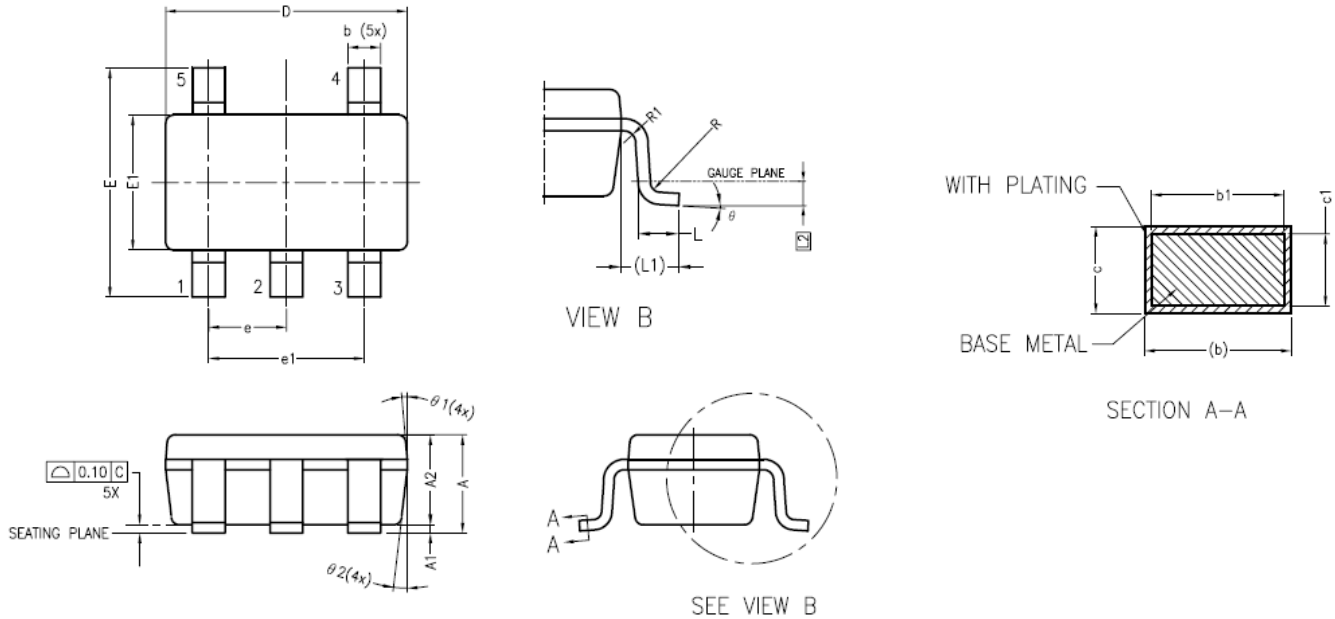

Figure 39. 5-Lead SOT23 Package Drawing

Table 4. CT8152 5-Lead SOT23 Package Dimensions

Symbol	Dimensions in Millimeters (mm)		
	Min.	Typ.	Max.
A	1.05	1.20	1.35
A1	0.00	0.10	0.15
A2	1.00	1.10	1.20
b	0.30	-	0.50
b1	0.30	0.35	0.45
c	0.08	-	0.22
c1	0.08	0.13	0.20
D	2.80	2.90	3.00
E	2.60	2.80	3.00
E1	1.50	1.60	1.70
e	0.95 BSC		
e1	1.90 BSC		
L	0.35	0.43	0.60
L1	0.60 REF		
L2	0.25 BSC		
R	0.10	-	-
R1	0.10	-	0.25
theta	0°	4°	8°
theta1	5°	6°	15°
theta2	5°	8°	15°

Crocus Technology provides package drawings as a service to customers considering or planning to use Crocus products in their designs. Drawings may change without notice. Please note the revision and date of the data sheet and contact a Crocus Technology representative to verify or obtain the most recent version. The package specifications do not expand the terms of Crocus Technology's worldwide terms and conditions, specifically the warranty therein, which covers Crocus Technology's products.

SOT23-5 Tape & Pocket Drawing and Dimensions

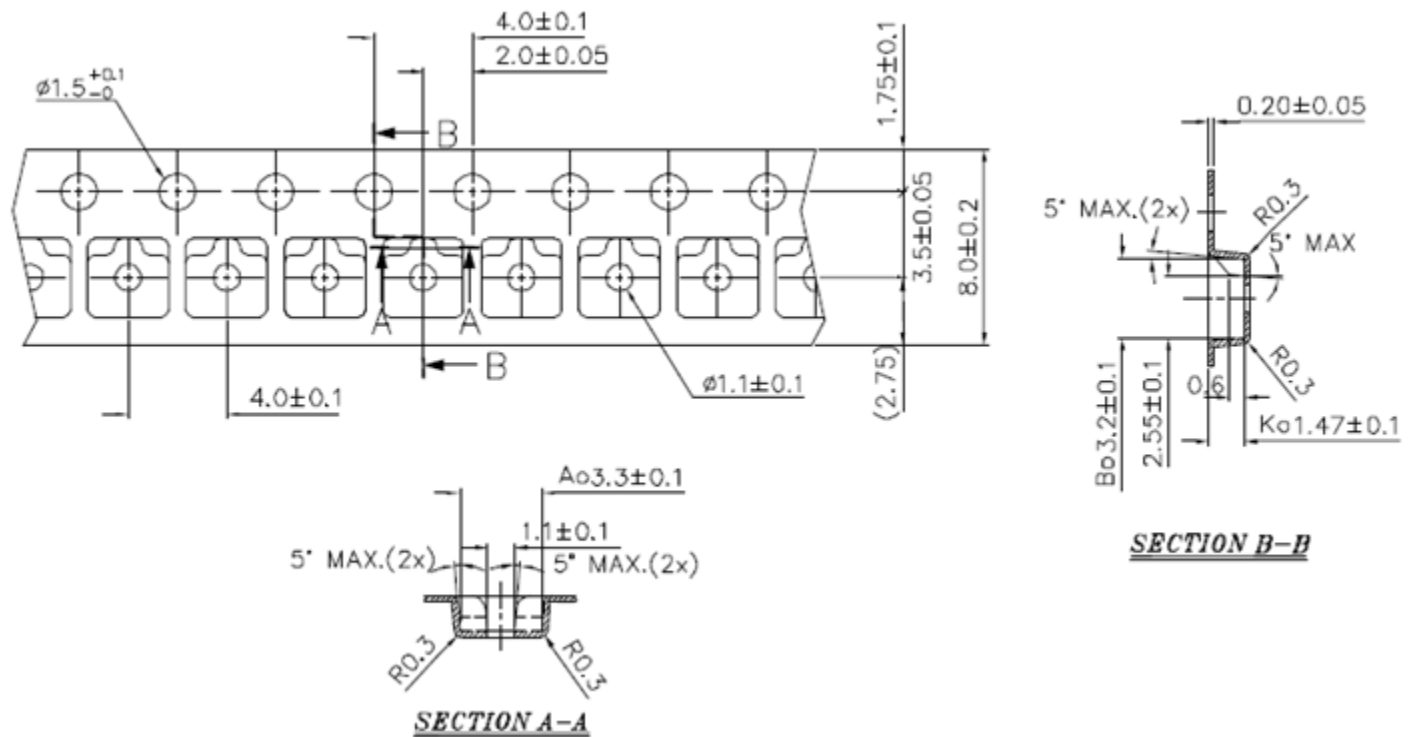

NOTES:

1. Material: Conductive Polystyrene
2. Dimensions in mm.
3. 10 sprocket hole pitch cumulative tolerance ± 0.20 mm.
4. Camber bot to exceed 1 mm in 100 mm.
5. Pocket position relative to sprocket hole measured as true position of pocket and not pocket hole.
6. (S.R. Ω/sq) means surface electric resistivity of the carrier tape.

Figure 40. Tape and Pocket Drawing for 5-lead SOT23 Package

Package Information

Table 5. CT815x Package Information

Part Number	Package Type	# of Leads	Package Quantity	Lead Finish	Eco Plan ⁽¹⁾	MSL Rating ⁽²⁾	Operating Temperature ⁽³⁾	Device Marking
CT8150PC-IS3	SOT23	3	3,000	Sn	Green & RoHS	1	-40°C to +85°C	MH YWWS
CT8150PC-HS3	SOT23	3	3,000	Sn	Green & RoHS	1	-40°C to +125°C	MH YWWS
CT8150PC-IL4	LGA	4	3,000	Au	Green & RoHS	3	-40°C to +85°C	P YZ
CT8150PC-HL4	LGA	4	3,000	Au	Green & RoHS	3	-40°C to +125°C	P YZ
CT8152PC-IS5	LGA	5	3,000	Au	Green & RoHS	1	-40°C to +85°C	MK YWWS
CT8152PC-HS5	LGA	5	3,000	Au	Green & RoHS	1	-40°C to +125°C	MK YWWS
CT8152PC-IL4	LGA	4	3,000	Au	Green & RoHS	3	-40°C to +85°C	R YZ
CT8152PC-HL4	LGA	4	3,000	Au	Green & RoHS	3	-40°C to +125°C	R YZ

- (1) RoHS is defined as semiconductor products that are compliant to the current EU RoHS requirements. It also will meet the requirement that RoHS substances do not exceed 0.1% by weight in homogeneous materials. Green is defined as the content of Chlorine (Cl), Bromine (Br) and Antimony Trioxide based flame retardants satisfy JS709B low halogen requirements of $\leq 1,000$ ppm.
- (2) MSL Rating = Moisture Sensitivity Level Rating as defined by JEDEC standard classifications.
- (3) Package will withstand ambient temperature range of -40°C to +150°C and storage temperature range of -65°C to +150°C.
- (4) Device Marking for SOT23 is defined as XZ YWWS where XZ = part number, Y = year, WW = work week and S = sequential number. LGA is defined as X where X = part number and YZ = date code information.

Disclaimer: The contents of this document are provided for informational purposes only. CROCUS TECHNOLOGY, INC. AND CROCUS TECHNOLOGY SA (COLLECTIVELY “CROCUS”) MAKE NO REPRESENTATIONS OR WARRANTY OF ANY KIND, EXPRESS OR IMPLIED, WITH RESPECT TO THE ACCURACY OR COMPLETENESS OF THE CONTENTS HEREIN, INCLUDING, BUT NOT LIMITED TO, THE IMPLIED WARRANTIES OF MERCHANTABILITY AND FITNESS FOR A PARTICULAR PURPOSE. Crocus reserves the right to make changes to the specifications and product descriptions, and/or to discontinue or make changes to its products at any time without notice. Crocus’s products have not been designed, tested, or manufactured for use and should not be used in applications where the failure, malfunction or inaccuracy of the Products carries a risk of death or serious bodily injury or damage to tangible property, including, but not limited to, life support systems, nuclear facilities, military, aircraft navigation or communication, emergency systems, harsh environments, or other applications with a similar degree of potential hazard.

Product Status Definition

Data Sheet Identification	Product Status	Definition
Objective	Proposed New Product Idea or In Development	Data sheet contains design target specifications and are subject to change without notice at any time.
Preliminary	First Production	Data sheet contains preliminary specifications obtained by measurements of early samples. Follow-on data will be published at a later date as more test data is acquired. Crocus reserves the right to make changes to the data sheet at any time.
None	Full Production	Data sheet contains final specifications for all parameters. Crocus reserves the right to make changes to the data sheet at any time.
Obsolete	Not in Production	Data sheet for a product that is no longer in production at Crocus. It is for reference only.