

SECTION A-A
SCALE 0.9 : 1

REV.	MODIFICATION.	DATE	DRN
01	PRODUCTION RELEASED	14/12/94	PTG
02	SCN2002-074	14/11/02	I.C
03	SCN2003-004	10/01/03	I.C
04	ECR2005-094	31/08/05	O.W
05	CO2010298	29/07/08	S.F

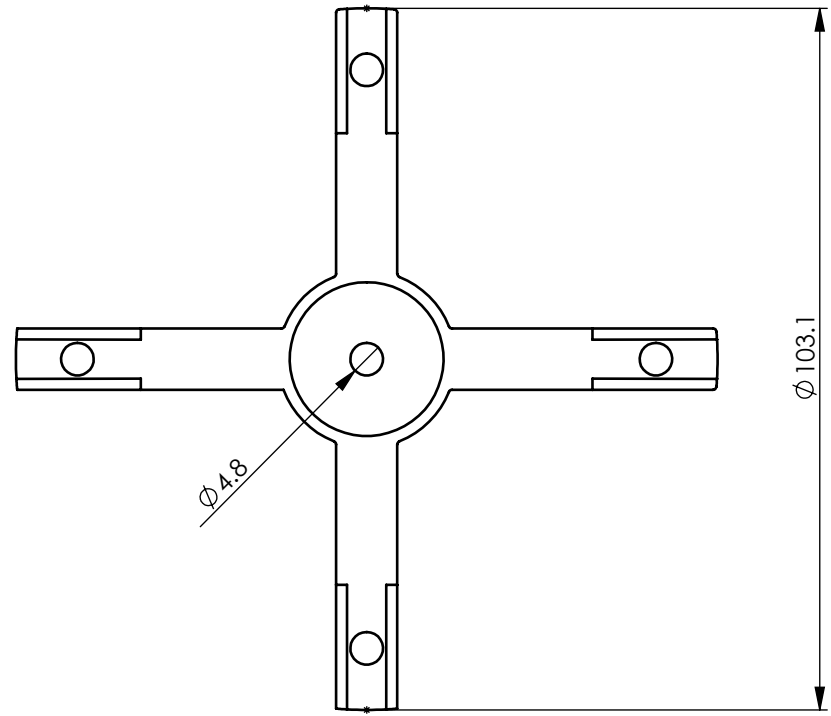

INFORMATION CONTAINED IN THIS DOCUMENT IS CONFIDENTIAL TO RICHCO INTERNATIONAL Co. Ltd. AND MAY NOT BE DISCLOSED OR REPRODUCED IN WHOLE OR PART WITHOUT THEIR WRITTEN CONSENT.



ALL DIMENSIONS IN mm
GENERAL TOLERANCES ± 0.25
UNLESS OTHERWISE STATED
1 DECIMAL PLACE \pm
2 DECIMAL PLACES \pm
ANGULAR $\pm 1^\circ$

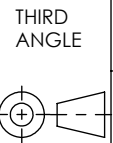

MATERIAL		ADHESIVE DETAILS	COLOUR	MOUNTING STYLE
NYLON 6/6 UL94-V2 RMS-01	NYLON 6/6UL94-V0 RMS-19			
OFSB-4-85-01A2-RT	OFSB-4-85-19A2-RT	Acrylic Adhesive, White PE Film Liner (RMS-24)	NATURAL	ADHESIVE TAPE
OFSB-4-85-01	OFSB-4-85-19	N/A		SCREW MOUNT

MATERIAL: See table		COLOUR: NATURAL	
DESCRIPTION: ADAPTOR PLATE - FIBRE SPIDER		PART NO: SEE TABLE	
DRG No: 999-0042	NPR No: N/A	SHEET SIZE A4	
DRN OW	DATE 31/08/05	CHKD TC	DATE 31/08/05
SCALE NTS	SHEET No. 1 OF 1		