

PXAE183708NB

Thermally-Enhanced High Power RF LDMOS FET 320 W, 28 V, 1805 – 1880 MHz

Description

The PXAE183708NB is a 320-watt LDMOS FET intended for use in multi-standard cellular power amplifier applications in the 1805 to 1880 MHz frequency band. Features include input and output matching, high gain and thermally-enhanced package with earless flange. Manufactured with Wolfspeed's advanced LDMOS process, this device provides excellent thermal performance and superior reliability.

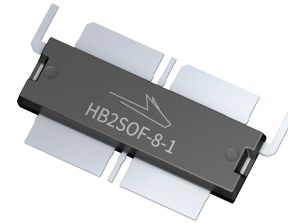

PXAE183708NB
Package PG-HB2SOF-8-1

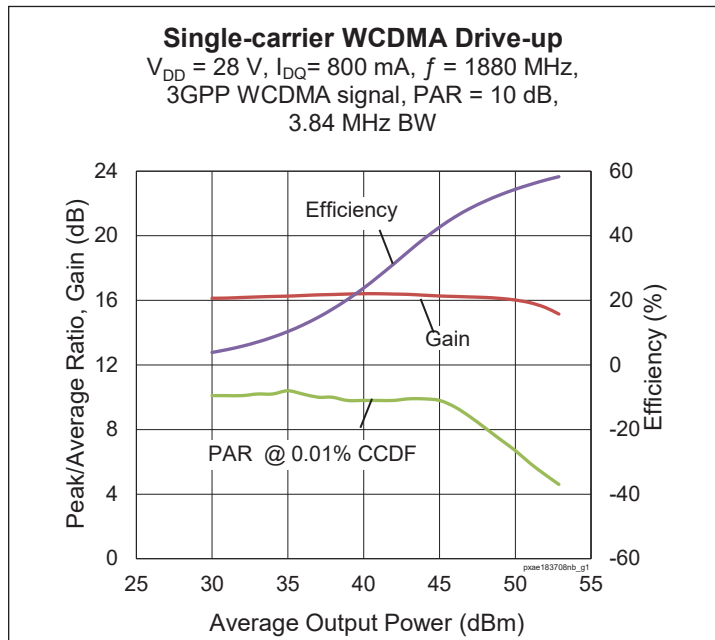

Features

- Broadband internal input and output matching
- Asymmetrical Doherty design
 - Main: $P_{3dB} = 160\text{ W Typ}$
 - Peak: $P_{3dB} = 315\text{ W Typ}$
- Typical Pulsed CW performance, 1880 MHz, 28 V, Doherty configuration, 10 μs pulse width, 10% duty cycle, Class AB (main), Class C (peak)
 - Output power at $P_{1dB} = 320\text{ W}$
 - Output power at $P_{3dB} = 430\text{ W}$
 - Drain efficiency = 60%
 - Gain = 13.5 dB
- Capable of handling 10:1 VSWR @ 28 V, 54 W (1C WCDMA) output power
- Human Body Model Class 2 (per ANSI/ESDA/JEDEC JS-001)
- Integrated ESD protection
- Low thermal resistance
- Pb-free and RoHS compliant

RF Characteristics

Single-carrier WCDMA Specifications (tested in Wolfspeed Doherty production test fixture)

$V_{DD} = 28\text{ V}$, $I_{DQ} = 800\text{ mA}$, $P_{OUT} = 54\text{ W avg}$, $V_{GSPK} = 1.5\text{ V}$, $f = 1880\text{ MHz}$, 3GPP signal, channel bandwidth = 3.84 MHz, peak/average = 10 dB @ 0.01% CCDF

| Characteristic | Symbol | Min | Typ | Max | Unit |
|---|----------|------|-------|-----|------|
| Gain | G_{ps} | 15.3 | 16 | — | dB |
| Drain Efficiency | η_D | 48 | 50.5 | — | % |
| Adjacent Channel Power Ratio | ACPR | — | -29.5 | -25 | dBc |
| Output PAR at 0.01% probability on CCDF | OPAR | 6.8 | 7.7 | — | dB |

All published data at $T_{CASE} = 25^\circ\text{C}$ unless otherwise indicated

ESD: Electrostatic discharge sensitive device—observe handling precautions!



DC Characteristics

| Characteristic | Conditions | Symbol | Min | Typ | Max | Unit |
|--------------------------------|--|---------------|-----|------|-----|---------------|
| Drain-Source Breakdown Voltage | $V_{GS} = 0\text{ V}, I_{DS} = 10\text{ mA}$ | $V_{(BR)DSS}$ | 65 | — | — | V |
| Drain Leakage Current | $V_{DS} = 28\text{ V}, V_{GS} = 0\text{ V}$ | I_{DSS} | — | — | 1 | μA |
| | $V_{DS} = 60\text{ V}, V_{GS} = 0\text{ V}$ | I_{DSS} | — | — | 10 | μA |
| Gate Leakage Current | $V_{GS} = 10\text{ V}, V_{DS} = 0\text{ V}$ | I_{GSS} | — | — | 1 | μA |
| On-State Resistance (main) | $V_{GS} = 10\text{ V}, V_{DS} = 0.1\text{ V}$ | $R_{DS(on)}$ | — | 0.08 | — | Ω |
| | (peak) $V_{GS} = 10\text{ V}, V_{DS} = 0.1\text{ V}$ | $R_{DS(on)}$ | — | 0.04 | — | Ω |
| Operating Gate Voltage (main) | $V_{DS} = 28\text{ V}, I_{DQ} = 800\text{ mA}$ | V_{GS} | 2.7 | 2.9 | 3.3 | V |
| | (peak) $V_{DS} = 28\text{ V}, I_{DQ} = 0\text{ mA}$ | V_{GS} | — | 1.5 | — | V |

Maximum Ratings

| Parameter | Symbol | Value | Unit |
|---------------------------|-----------|-------------|--------------------|
| Drain-Source Voltage | V_{DSS} | 65 | V |
| Gate-Source Voltage | V_{GS} | -6 to +10 | V |
| Operating Voltage | V_{DD} | 0 to +32 | V |
| Junction Temperature | T_J | 225 | $^{\circ}\text{C}$ |
| Storage Temperature Range | T_{STG} | -65 to +150 | $^{\circ}\text{C}$ |

Thermal Characteristics

| Characteristic | Symbol | Value | Unit |
|---|-----------------|-------|----------------------|
| Thermal Resistance (Main, $T_{CASE} = 70^{\circ}\text{C}, 54\text{ W CW}$) | $R_{\theta JC}$ | 0.63 | $^{\circ}\text{C/W}$ |

Moisture Sensitivity Level

| Level | Test Signal | Package Temperature | Unit |
|-------|---------------------|---------------------|--------------------|
| 3 | IPC/JEDEC J-STD-020 | 260 | $^{\circ}\text{C}$ |

Ordering Information

| Type and Version | Order Code | Package | Shipping |
|--------------------|--------------------|---------------|----------------------|
| PXAE183708NB V1 R2 | PXAE183708NB-V1-R2 | PG-HB2SOF-8-1 | Tape & Reel, 250 pcs |

Typical Performance (data taken in test fixture)

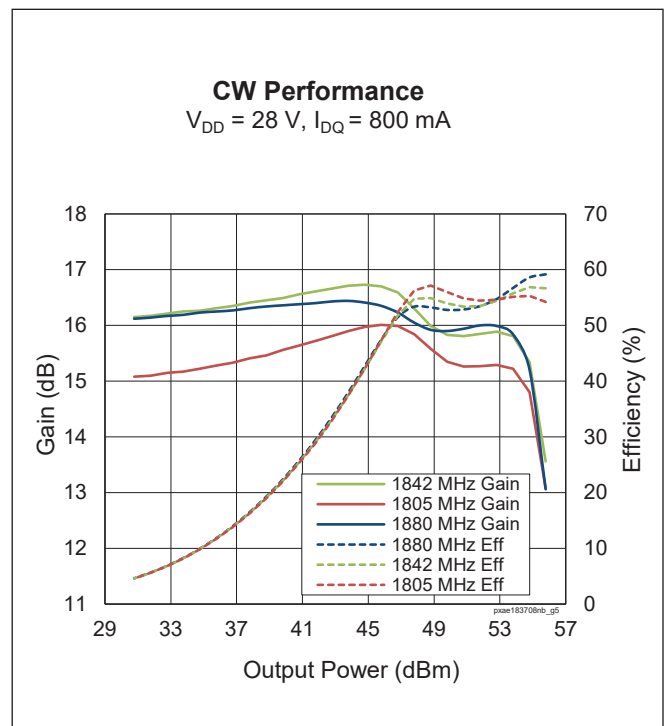
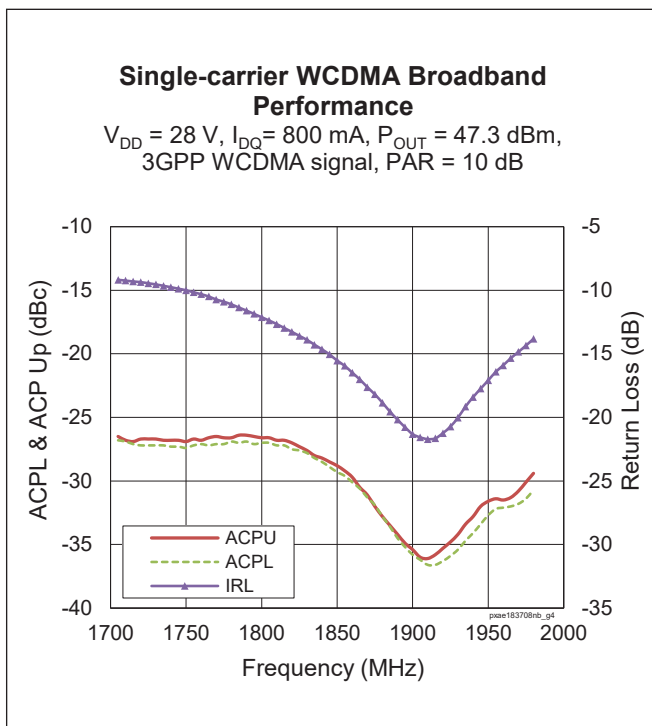
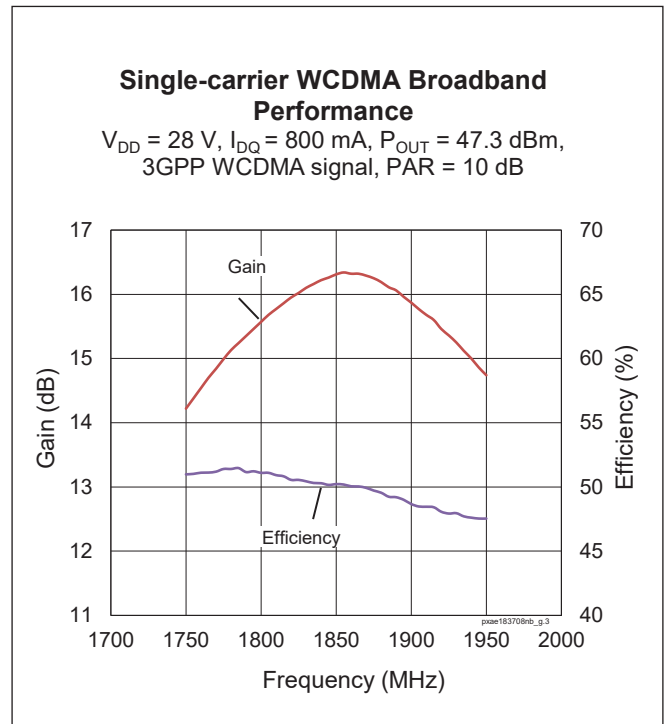
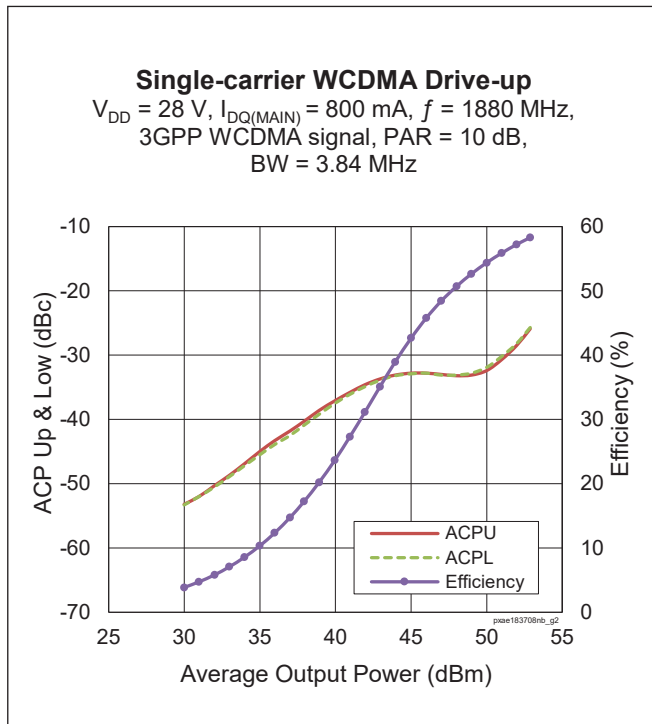

Typical Performance (data taken in test fixture)

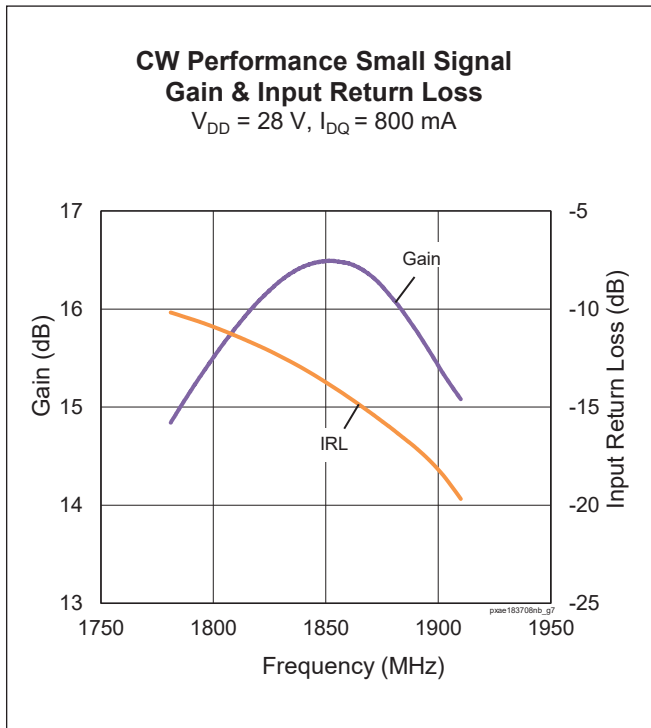

Load Pull Performance

Main Side Load Pull Performance – Pulsed CW signal: 10 μ s, 10% duty cycle, 28 V, I_{DQ} = 850 mA, class AB

| | | P_{1dB} | | | | | | | | | |
|-------------------|--------------------------|--------------------------|------------------|------------------------------|----------------------------|--|-----------------------------|------------------|------------------------------|----------------------------|--|
| | | Max Output Power | | | | | Max Drain Efficiency | | | | |
| Freq [MHz] | Z_s [W] | Z_L [W] | Gain [dB] | P_{1dB} [dBm] | P_{1dB} [W] | η_D [%] | Z_L [W] | Gain [dB] | P_{1dB} [dBm] | P_{1dB} [W] | η_D [%] |
| 1805 | 4.4-j10.8 | 1.2-j2.5 | 19.4 | 52.30 | 171 | 57.6 | 2.4-j1.3 | 21.9 | 50.10 | 103 | 68.4 |
| 1842.5 | 7.4-j13.2 | 1.2-j2.7 | 19.2 | 52.30 | 170 | 56.7 | 2.1-j1.5 | 21.7 | 50.50 | 112 | 67.9 |
| 1880 | 16.8-j14.6 | 1.2-j2.9 | 19.3 | 52.20 | 165 | 55.9 | 2.1-j1.7 | 21.7 | 50.30 | 106 | 65.8 |

| | | P_{3dB} | | | | | | | | | |
|-------------------|--------------------------|--------------------------|------------------|------------------------------|----------------------------|--|-----------------------------|------------------|------------------------------|----------------------------|--|
| | | Max Output Power | | | | | Max Drain Efficiency | | | | |
| Freq [MHz] | Z_s [W] | Z_L [W] | Gain [dB] | P_{3dB} [dBm] | P_{3dB} [W] | η_D [%] | Z_L [W] | Gain [dB] | P_{3dB} [dBm] | P_{3dB} [W] | η_D [%] |
| 1805 | 4.4-j10.8 | 1.2-j2.6 | 17.3 | 53.20 | 209 | 60.5 | 2.1-j1.9 | 19.3 | 51.90 | 155 | 71.0 |
| 1842.5 | 7.4-j13.2 | 1.2-j2.9 | 17.2 | 53.10 | 204 | 58.9 | 2.0-j1.7 | 19.5 | 51.60 | 144 | 70.6 |
| 1880 | 16.8-j14.6 | 1.3-j3.0 | 17.4 | 53.00 | 200 | 59.4 | 2.0-j1.9 | 19.4 | 51.60 | 143 | 69.0 |

Peak Side Load Pull Performance – Pulsed CW signal: 10 μ s, 10% duty cycle, 28 V, $V_{GS(PEAK)}$ = 2.4 V, class B

| | | P_{1dB} | | | | | | | | | |
|-------------------|--------------------------|--------------------------|------------------|------------------------------|----------------------------|--|-----------------------------|------------------|------------------------------|----------------------------|--|
| | | Max Output Power | | | | | Max Drain Efficiency | | | | |
| Freq [MHz] | Z_s [W] | Z_L [W] | Gain [dB] | P_{1dB} [dBm] | P_{1dB} [W] | η_D [%] | Z_L [W] | Gain [dB] | P_{1dB} [dBm] | P_{1dB} [W] | η_D [%] |
| 1805 | 2.9-j6.7 | 2.0-j4.5 | 17.4 | 54.90 | 306 | 56.0 | 2.2-j1.7 | 18.9 | 52.20 | 164 | 69.1 |
| 1842.5 | 5.4-j7.1 | 2.4-j4.8 | 17.6 | 54.80 | 305 | 54.4 | 2.1-j2.1 | 19.2 | 52.60 | 181 | 69.0 |
| 1880 | 8.4-j4.2 | 2.4-j4.9 | 17.9 | 54.80 | 300 | 55.4 | 2.1-j2.2 | 19.3 | 52.20 | 166 | 68.3 |

| | | P_{3dB} | | | | | | | | | |
|-------------------|--------------------------|--------------------------|------------------|------------------------------|----------------------------|--|-----------------------------|------------------|------------------------------|----------------------------|--|
| | | Max Output Power | | | | | Max Drain Efficiency | | | | |
| Freq [MHz] | Z_s [W] | Z_L [W] | Gain [dB] | P_{3dB} [dBm] | P_{3dB} [W] | η_D [%] | Z_L [W] | Gain [dB] | P_{3dB} [dBm] | P_{3dB} [W] | η_D [%] |
| 1805 | 2.9-j6.7 | 2.4-j4.6 | 15.3 | 55.70 | 369 | 59.1 | 2.6-j2.1 | 16.7 | 53.70 | 234 | 68.8 |
| 1842.5 | 5.4-j7.1 | 2.5-j4.8 | 15.6 | 55.60 | 366 | 57.7 | 2.6-j2.6 | 16.9 | 54.20 | 260 | 68.3 |
| 1880 | 8.4-j4.2 | 2.9-5.1 | 15.7 | 55.50 | 357 | 57.5 | 2.5-j2.7 | 17.1 | 53.90 | 245 | 68.4 |

Reference Circuit, 1805 – 1880 MHz

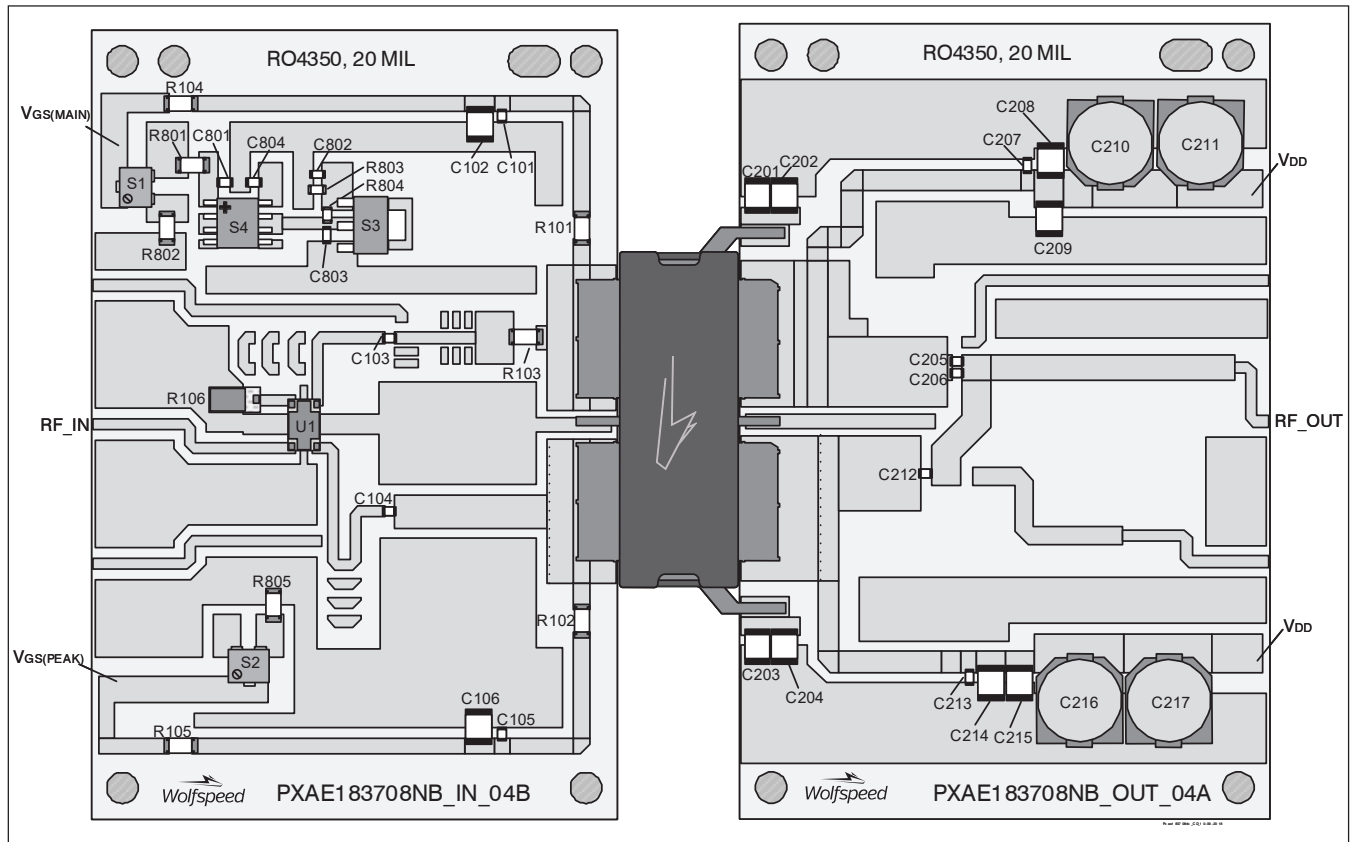

Reference circuit assembly diagram (not to scale)

Reference Circuit Assembly

| | |
|---|---|
| DUT | PXAE183708NB-V1 |
| Test Fixture Part No. | LTA/PXAE183708NB-V1 |
| PCB | Rogers 4350, 0.508 mm [0.020"] thick, 2 oz. copper, $\epsilon_r = 3.66$, $f = 1805 - 1800$ MHz |
| Find Gerber files for this test fixture on the Wolfspeed Web site at www.wolfspeed.com/RF | |



Reference Circuit, 1805 – 1880 MHz

Components Information

| Component | Description | Manufacturer | P/N |
|--|-------------------------|----------------------------------|---------------------|
| Input | | | |
| C101, C105 | Capacitor, 33 pF | ATC | ATC800A330JT250XT |
| C102, C106 | Capacitor, 10 μF, 50 V | Taiyo Yuden | UMK325C7106MM-T |
| C103, C104 | Capacitor, 22 pF | ATC | ATC800A220JT250XT |
| R101, R102 | Resistor, 5.1 ohms | Panasonic Electronic Components | ERJ-8GEYJ5R1V |
| R103, R104, R105 | Resistor, 10 ohms | Panasonic Electronic Components | ERJ-8GEYJ100V |
| R106 | Resistor, 50 ohms | Richardson | C16A50Z4 |
| C801, C802, C803, C804 | Capacitor, 1000 pF | Murata Electronics North America | GRM188R71H102KA01J |
| R801 | Resistor, 1K ohms | Panasonic Electronic Components | ERJ-8GEYJ102V |
| R802 | Resistor, 51 ohms | Panasonic Electronic Components | ERJ-8GEYJ510V |
| R803 | Resistor, 1.3K ohms | Panasonic Electronic Components | ERJ-3GEYJ132V |
| R804 | Resistor, 1.2K ohms | Panasonic Electronic Components | ERJ-3GEYJ122V |
| R805 | Resistor, 10 ohms | Panasonic Electronic Components | ERJ-8GEYJ100V |
| S1, S2 | Potentiometer, 2K ohms | Bourns Inc. | 3224W-1-202E |
| S3 | Voltage Regulator | Texas Instruments | LM78L05ACM |
| S4 | Transistor | Diodes Incorporated | BCP5616TA |
| U1 | Hybrid coupler | Anaren | X3C20F1-02S |
| Output | | | |
| C201, C202, C203, C204, C208, C209, C214, C215 | Capacitor, 10 μF, 100 V | TDK Corporation | C5750X7S2A106M230KB |
| C205, C206 | Capacitor, 2.4 pF | ATC | ATC800A2R4CT250XT |
| C207, C212, C213 | Capacitor, 33 pF | ATC | ATC800A330JT250XT |
| C210, C211, C216, C217 | Capacitor, 220 μF | Panasonic Electronic Components | EEE-FP1V221AP |

Pinout Diagram (top view)

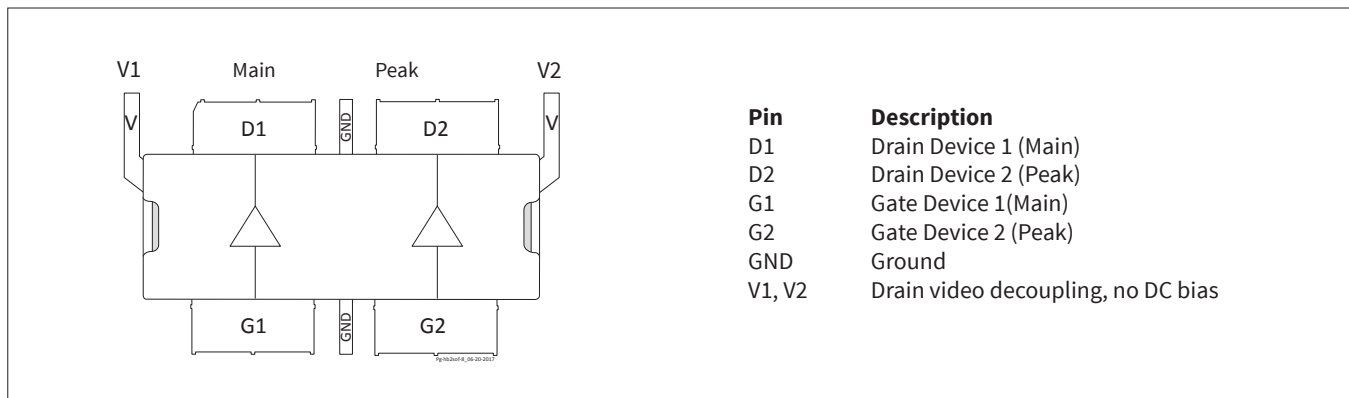

Lead connections for PXAE183708NB

Package Outline Specifications

Package PG-HB2SOF-8-1

Top and Side View

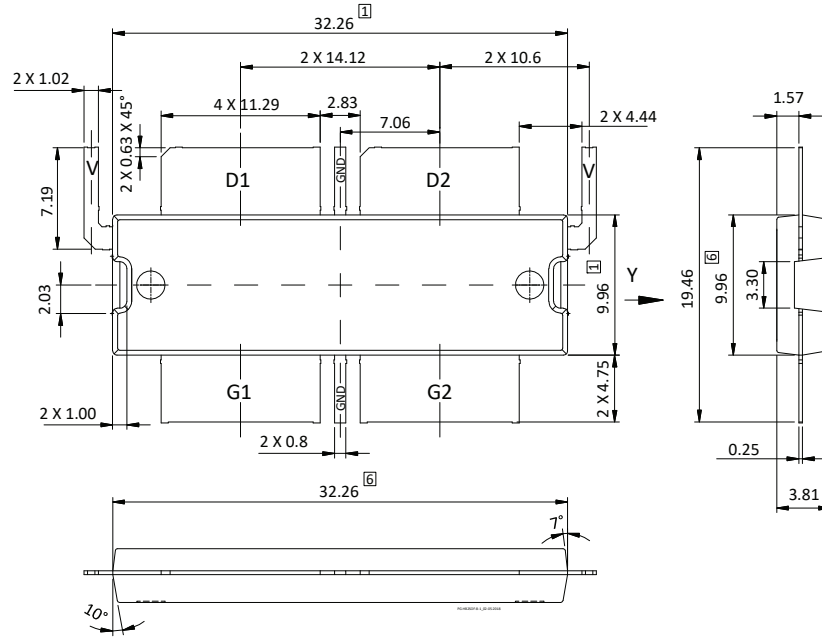

Bottom View

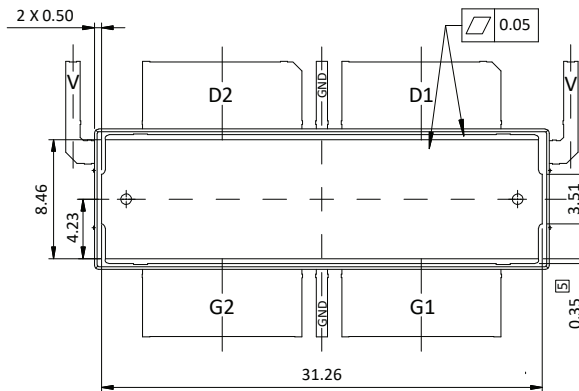

Diagram Notes—unless otherwise specified:

- 1. Mold/Dam Bar/Metal protusion of 0.30mm max per side not included.
- 2. Fillets and radii: all radii are 0.3 mm max unless specified otherwise
- 3. Interpret dimensions and tolerances per ISO 8015
- 4. Dimensions are mm
- 5. Exposed metal surface are tin plated, may not be covered by mold compound
- 6. Does not include mold/dam bar/metal protusion.
- 7. All tolerances ± 0.1 mm unless specified otherwise
- 9. All metal surfaces pre-plated, except area of cut
- 9. Lead thickness: 0.25 mm
- 10. Pins: D1, D2 – drain; G1, G2 – gate; GND – ground; V – Drain video decoupling, no DC bias



Revision History

| Revision | Date | Data Sheet Type | Page | Subjects (major changes since last revision) |
|----------|------------|-----------------|------|---|
| 01 | 2018-03-26 | Advance | All | Data Sheet reflects advance specification for product development |
| 02 | 2018-04-26 | Advance | All | Converted to Wolfspeed Data Sheet |
| 03 | 2019-02-07 | Production | All | Data Sheet reflects released product specification |

For more information, please contact:

4600 Silicon Drive
 Durham, North Carolina, USA 27703
www.wolfspeed.com/RF

Sales Contact
RFSales@wolfspeed.com

RF Product Marketing Contact
RFMarketing@wolfspeed.com
 919.407.7816

Notes

Disclaimer

Specifications are subject to change without notice. Cree, Inc. believes the information contained within this data sheet to be accurate and reliable. However, no responsibility is assumed by Cree for any infringement of patents or other rights of third parties which may result from its use. No license is granted by implication or otherwise under any patent or patent rights of Cree. Cree makes no warranty, representation or guarantee regarding the suitability of its products for any particular purpose. “Typical” parameters are the average values expected by Cree in large quantities and are provided for information purposes only. These values can and do vary in different applications and actual performance can vary over time. All operating parameters should be validated by customer’s technical experts for each application. Cree products are not designed, intended or authorized for use as components in applications intended for surgical implant into the body or to support or sustain life, in applications in which the failure of the Cree product could result in personal injury or death or in applications for planning, construction, maintenance or direct operation of a nuclear facility.

Mouser Electronics

Authorized Distributor

Click to View Pricing, Inventory, Delivery & Lifecycle Information:

[Wolfspeed:](#)

[PXAE183708NB-V1-R2](#)