

GENERAL-PURPOSE MICRO SWITCHES Z-15 SERIES

Specifications

Operating Speed	0.01mm-1m/sec
Operating Frequency	Mechanical: 240ops/min Electrical: 20 ops/min
Insulation Resistance	>100MΩ@500V DC
Contact Resistance	<15mΩ
Rated Current/Voltage	15A,125/250/480VAC;3/4HP/125VAC 1.5HP/250VAC (UL file E321073)
Dielectric Strength	1000VAC for 1 min between current carrying parts 2500VAC for 1 min between non-current carrying parts
Service Life	Mechanically 1.0 x 10 ⁷ (operations) Electrically 5 x 10 ⁵ (operations)
Operating Temperature	-40~+105°C (-40~221°F) High temp. model available up to 204°C (400°F)
Humidity	35-85%RH / 35-95%RH for -55 sealed version
Degree of Protection	IP40 / IP64 for -55 sealed version

Definitions of Operating Characteristics

OF	Operating Force	PT	Pretravel
RF	Releasing Force	MD	Movement Differential
OT	Overtravel	OP	Operating Position
TT	Total Travel		

Rated indicators Z-15G

Operating voltage	Non-inductive load (A)				Inductive load (A)			Inrush current		
	Resistive load		Bulb load		Inductive load		Motor load		NC	NO
	NC	NO	NC	NO	NC	NO	NC	NO		
125 VAC	15	3	1.5	15	5	2.5	30 Max	15 Max		
250 VAC	15	2.5	1.25	15	3	1.5				
500 VAC	10	1.5	0.75	6	1.5	0.75				
8 VDC	15	3	1.5	15	5	2.5				
14 VDC	15	3	1.5	10	5	2.5				
30 VDC	6	3	1.5	5	5	2.5				
125 VDC	0.5	0.5	0.5	0.05	0.05	0.05				
250 VDC	0.25	0.25	0.25	0.03	0.03	0.03				

Selection Guide:

Z -	15	G	-	-	-	-	-	*
	Current	Actuating Style		Sealing	Contact Material	Reset	Terminal Style See Page 8 for Details	Circuitry
	15 15A 20 20A 25 25A		None Standard 55 Sealed	None Silver K Plated gold	None No Reset R Resettable with spring overtravel R1 Short reset R2 Long reset	None Screw terminal P0 Screw on soldering tab P1 Screw on soldering tab P2 Screw on soldering tab P3 Screw terminal P3 P4 Screw terminal P4 P5 Screw terminal P5 P6 Screw terminal P6 P7 Screw terminal P7 P8 Terminal Potted D6 QC terminal Q2 30° QC terminal S1 Screw Terminal	none 1NO/1NC X 1NC Y 1NO	

*add (US) as suffix to have US standard ø3.55 mounting holes

Circuitry:

-X 1NC only

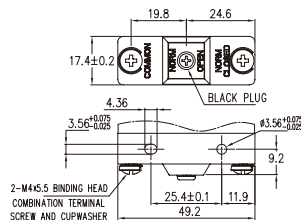

-Y 1NO only

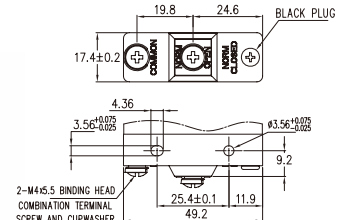

GENERAL-PURPOSE MICRO SWITCHES

Z-15 SERIES

Product Dimensions Unit: mm

<p>Z-15G</p> <p>Operating Characteristics</p> <ul style="list-style-type: none"> • OF_{max} 3.43N • RF_{min} 1.12N • PT_{max} 0.4mm • OT_{min} 0.13mm • MD_{max} 0.05mm • OP 15.9±0.4mm 	<p>Z-15GD</p> <p>Operating Characteristics</p> <ul style="list-style-type: none"> • OF_{max} 3.43N • RF_{min} 1.12N • PT_{max} 0.4mm • OT_{min} 1.6mm • MD_{max} 0.05mm • OP 21.5±0.5mm
<p>Z-15GS</p> <p>Operating Characteristics</p> <ul style="list-style-type: none"> • OF_{max} 3.43N • RF_{min} 1.12N • PT_{max} 0.4mm • OT_{min} 1.6mm • MD_{max} 0.05mm • OP 28.2±0.6mm 	<p>Z-15GQ</p> <p>Operating Characteristics</p> <ul style="list-style-type: none"> • OF_{max} 3.43N • RF_{min} 1.12N • PT_{max} 0.4mm • OT_{min} 5.5mm • MD_{max} 0.05mm • OP 21.8±0.8mm
<p>Z-15GQ21</p> <p>Operating Characteristics</p> <ul style="list-style-type: none"> • OF_{max} 3.43N • RF_{min} 1.12N • PT_{max} 0.4mm • OT_{min} 3.58mm • MD_{max} 0.05mm • OP 33.4±1.2mm 	<p>Z-15GQ22</p> <p>Operating Characteristics</p> <ul style="list-style-type: none"> • OF_{max} 3.43N • RF_{min} 1.12N • PT_{max} 0.4mm • OT_{min} 3.58mm • MD_{max} 0.05mm • OP 33.4±1.2mm
<p>Z-15GW</p> <p>Operating Characteristics</p> <ul style="list-style-type: none"> • OF_{max} 0.69N • RF_{min} 0.14N • PT_{max} 10mm • OT_{min} 5.6mm • MD_{max} 2mm • FP_{max} 28.2mm • OP 19.1±0.7mm 	<p>Z-15GW1</p> <p>Operating Characteristics</p> <ul style="list-style-type: none"> • OF_{max} 1.03N • RF_{min} 0.21N • PT_{max} 6.6mm • OT_{min} 3.7mm • MD_{max} 0.85mm • FP_{max} 24.5mm • OP 18.4±0.5mm

GENERAL-PURPOSE MICRO SWITCHES Z-15 SERIES

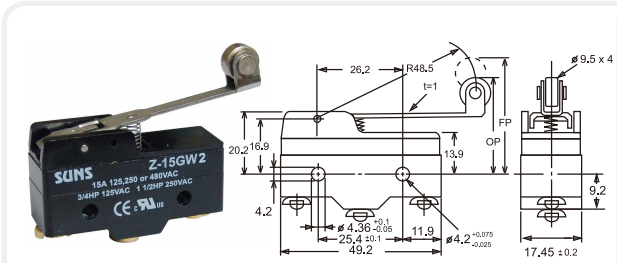

Z-15GW2

Operating Characteristics

- OF_{max} 0.98N
- RF_{min} 0.21N
- PT_{max} 7.1mm
- OT_{min} 4mm
- MD_{max} 1.02mm
- FP_{max} 36.5mm
- OP 30.2±0.8mm

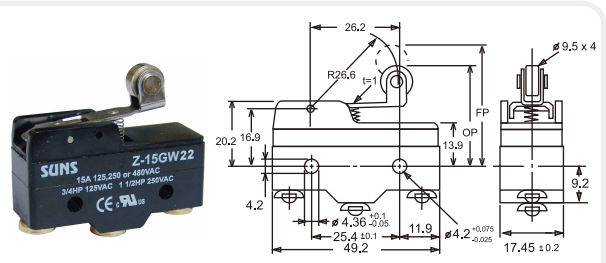

Z-15GW22

Operating Characteristics

- OF_{max} 1.57N
- RF_{min} 0.41N
- PT_{max} 2.7mm
- OT_{min} 2.4
- MD_{max} 0.8mm
- FP_{max} 32.5mm
- OP 30.2±0.4mm

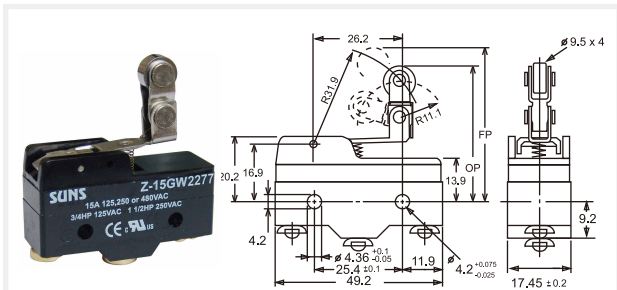

Z-15GW2277

Operating Characteristics

- OF_{max} 1.67N
- RF_{min} 0.41N
- PT_{max} 3mm
- OT_{min} 2.4mm
- MD_{max} 0.8mm
- FP_{max} 43.5mm
- OP 41.3±0.8mm

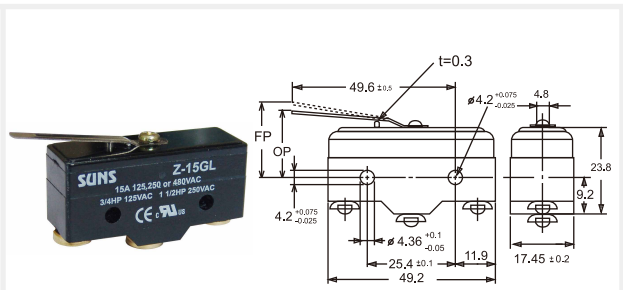

Z-15GL

Operating Characteristics

- OF_{max} 1.47N
- RF_{min} 0.14N
- PT_{max} 4mm
- OT_{min} 1.6mm
- MD_{max} 1.3mm
- FP 20.6mm
- OP 17.4±0.8mm

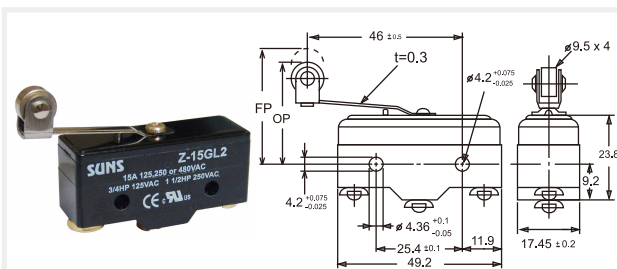

Z-15GL2

Operating Characteristics

- OF_{max} 1.47N
- RF_{min} 0.14N
- OT_{min} 1.6mm
- PT_{max} 4mm
- MD_{max} 1.3mm
- FP 31.8mm
- OP 28.6±0.8mm

GENERAL-PURPOSE MICRO SWITCHES Z-15 SERIES(SEALED TO IP64)

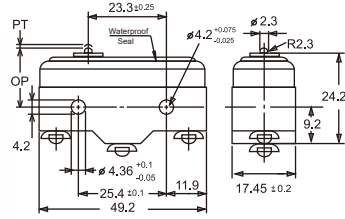

Z-15G-55

Operating Characteristics

- OF_{max} 3.43N
- RF_{min} 1.12N
- PT_{max} 0.4mm
- OT_{min} 0.13mm
- MD_{max} 0.05mm
- OP 15.9±0.4mm

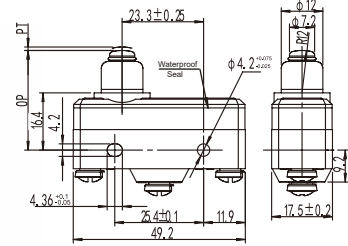

Z-15GK-55

Operating Characteristics

- OF_{max} 5.3N
- RF_{min} 1.11N
- OT_{min} 1.6mm
- PT_{max} 2.3mm
- MD_{max} 0.06mm
- OP 28.2±0.5mm

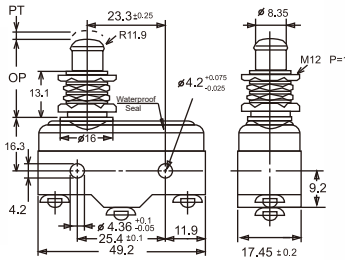

Z-15GQ-55

Operating Characteristics

- OF_{max} 3.43N
- RF_{min} 1.12N
- PT_{max} 0.4mm
- OT_{min} 5.5mm
- MD_{max} 0.05mm
- OP 21.8±0.8mm

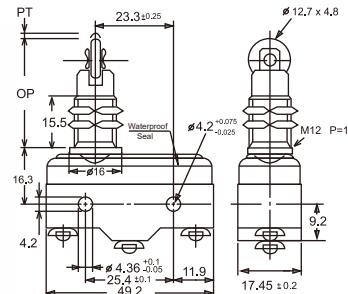

Z-15GQ21-55

Operating Characteristics

- OF_{max} 3.43N
- RF_{min} 1.12N
- PT_{max} 0.4mm
- OT_{min} 3.58mm
- MD_{max} 0.05mm
- OP 33.4±1.2mm

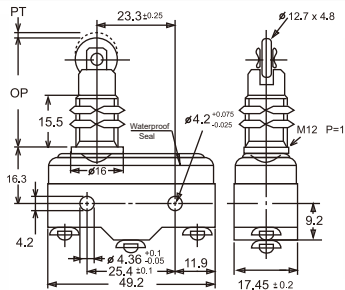

Z-15GQ22-55

Operating Characteristics

- OF_{max} 3.43N
- RF_{min} 1.12N
- PT_{max} 0.4mm
- OT_{min} 3.58mm
- MD_{max} 0.05mm
- OP 33.4±1.2mm

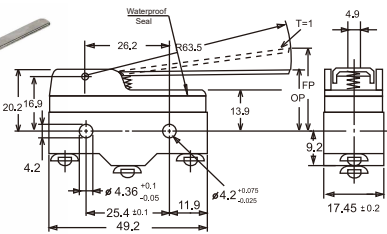

Z-15GW-55

Operating Characteristics

- OF_{max} 0.69N
- RF_{min} 0.14N
- PT_{max} 10mm
- OT_{min} 5.6mm
- MD_{max} 2mm
- FP_{max} 28.2mm
- OP 19.1±0.7mm

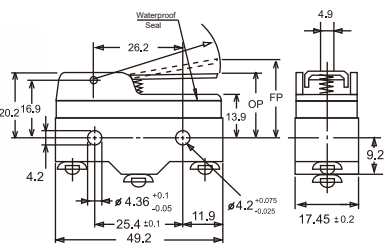

Z-15GW1-55

Operating Characteristics

- OF_{max} 1.03N
- RF_{min} 0.21N
- PT_{max} 6.6mm
- OT_{min} 3.7mm
- MD_{max} 0.85mm
- FP_{max} 24.5mm
- OP 18.4±0.5mm

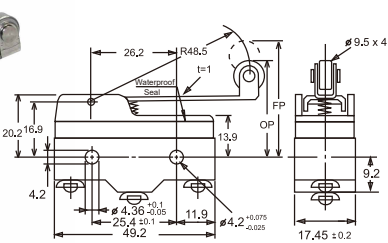

Z-15GW2-55

Operating Characteristics

- OF_{max} 0.98N
- RF_{min} 0.21N
- PT_{max} 7.1mm
- OT_{min} 4mm
- MD_{max} 1.02mm
- FP_{max} 36.5mm
- OP 30.2±0.8mm

GENERAL-PURPOSE MICRO SWITCHES Z-15 SERIES(SEALED TO IP64)

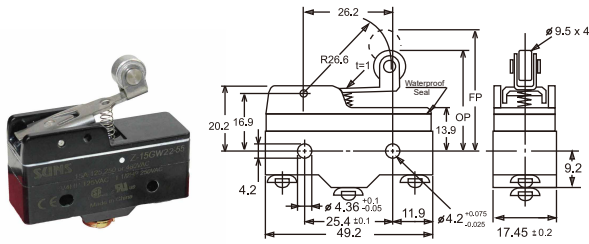

Z-15GW22-55

Operating Characteristics

- OF_{max} 1.57N
- RF_{min} 0.41N
- PT_{max} 2.7mm
- OT_{min} 2.4
- MD_{max} 0.8mm
- OP 30.2±0.4mm
- FP_{max} 32.5mm

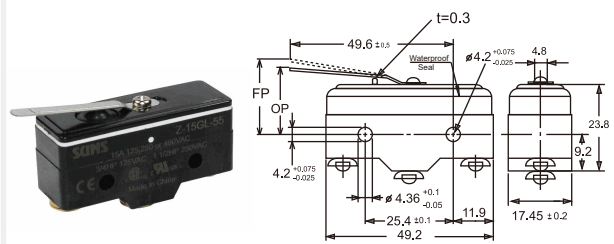

Z-15GL-55

Operating Characteristics

- OF_{max} 1.47N
- RF_{min} 0.14N
- PT_{max} 4mm
- OT_{min} 1.6mm
- MD_{max} 1.3mm
- OP 17.4±0.8mm
- FP 20.6mm

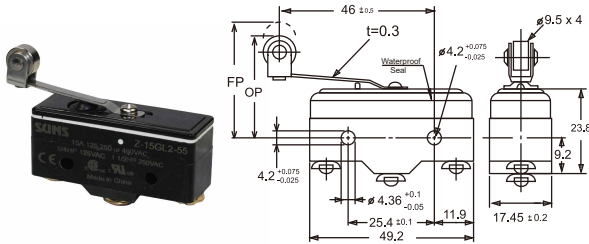

Z-15GL2-55

Operating Characteristics

- OF_{max} 1.47N
- RF_{min} 0.14N
- OT_{min} 1.6mm
- PT_{max} 4mm
- MD_{max} 1.3mm
- OP 28.6±0.8mm
- FP 31.8mm

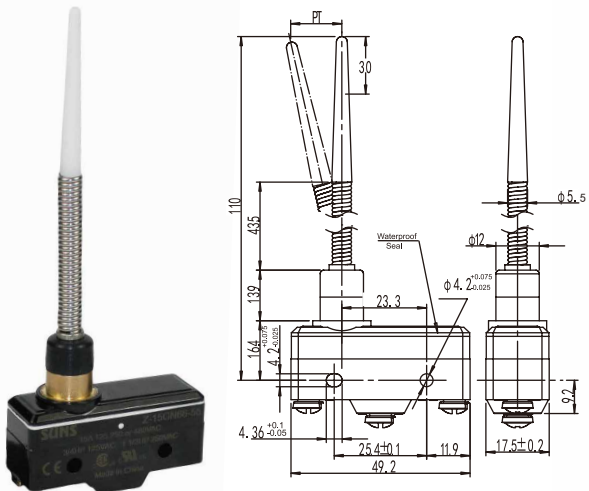

Z-15GN66-55

Operating Characteristics

- OF_{max} 0.7N
- PT_{max} 25mm

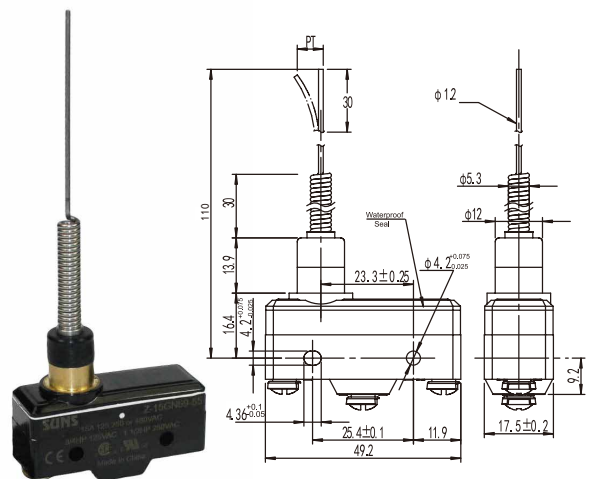

Z-15GN69-55

Operating Characteristics

- OF_{max} 0.7N
- PT_{max} 25mm

GENERAL-PURPOSE MICRO SWITCHES Z-20,Z-25 SERIES

Specifications

Operating Speed	0.01mm-1m/sec
Operating Frequency	Mechanical: 240ops/min Electrical: 20 ops/min
Insulation Resistance	>100MΩ@500V DC
Contact Resistance	<15mΩ
Rated Current/Voltage	20A/25A, 125/250/480VAC; 1-1/2HP/125VAC 2HP/250VAC (UL file E321073)
Dielectric Strength	1000VAC for 1 min between current carrying parts 2500VAC for 1 min between non-current carrying parts
Service Life	Mechanically 1.0 x 10 ⁷ (operations) Electrically 5 x 10 ⁵ (operations)
Operating Temperature	-40~+105°C (-40~211°F)
Humidity	35-85%RH / 35-95%RH for -55 sealed version
Degree of Protection	IP40 / IP64 for -55 sealed version

Definitions of Operating Characteristics

OF	Operating Force	PT	Pretravel
RF	Releasing Force	MD	Movement Differential
OT	Overtravel	OP	Operating Position
TT	Total Travel	PO	Travel to Positive Opening

Rated indicators

Operating voltage	Non-inductive load (A)				Inductive load (A)			
	Resistive load		Bulb load		Inductive load		Motor load	
	NC	NO	NC	NO	NC	NO	NC	NO
125 VAC	20(25)	20(25)	7.5	7.5	20(25)	20(25)	12.5	12.5
250 VAC	20(25)	20(25)	7.5	7.5	20(25)	20(25)	8.3	8.3
500 VAC	15	15	4	4	10	10	2	2
8 VDC	20(25)	20(25)	3	1.5	20(25)	20(25)	12.5	12.5
14 VDC	20(25)	20(25)	3	1.5	15	15	12.5	12.5
30 VDC	6	6	3	1.5	5	5	5	5
125 VDC	0.5	0.5	0.5	0.5	0.05	0.05	0.05	0.05
250 VDC	0.25	0.25	0.25	0.25	0.03	0.03	0.03	0.03
Inrush current	NC:75A max. NO:75A max				NC:75A approx. NO:75A max			

Dimensions Unit: mm

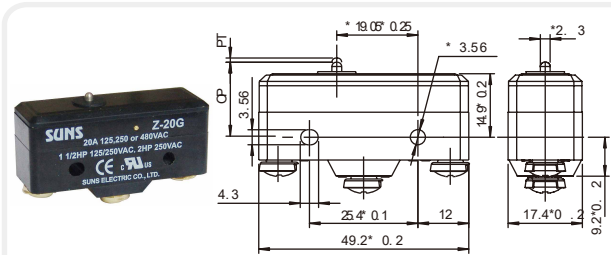

Z-20G & Z-25G Operating Characteristics

● CF	3.89*6. 11N	● OT(Min)	0.25mm
● RF(Min)	2.78N	● MD	0.05*0.2mm
● PT(Max)	1.3mm	● CP	16.27*0.4mm

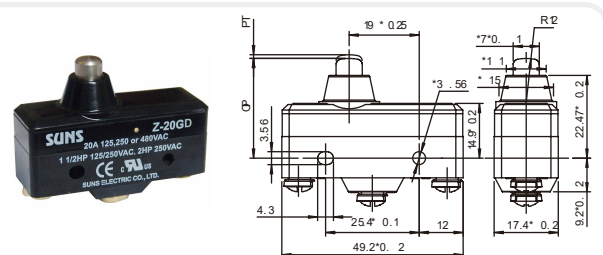

Z-20GD & Z-25GD Operating Characteristics

● CF	3.89*6. 11N	● OT(Min)	3.0mm
● RF(Min)	2.78N	● MD	0.05*0.2mm
● PT(Max)	1.3mm	● CP	26.2*0.5mm

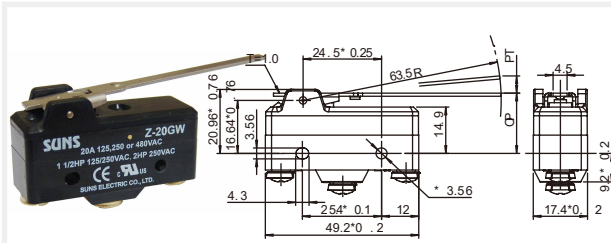

Z-20GW & Z-25GW Operating Characteristics

● OF(Max)	0.7N	● OT(Min)	1.98mm
● RF(Min)	0.14N	● MD(Max)	2.77mm
● PT(Max)	15.9mm	● CP	19.1*0.8mm

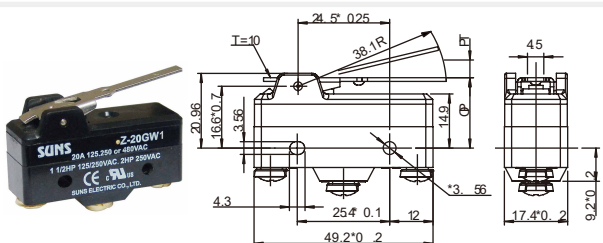

Z-20GW1 & Z-25GW1 Operating Characteristics

● CF(Max)	1.6N	● OT(Min)	1.2mm
● RF(Min)	0.4N	● MD(Max)	1.2mm
● PT(Max)	6.5mm	● CP	19.1*0.8mm

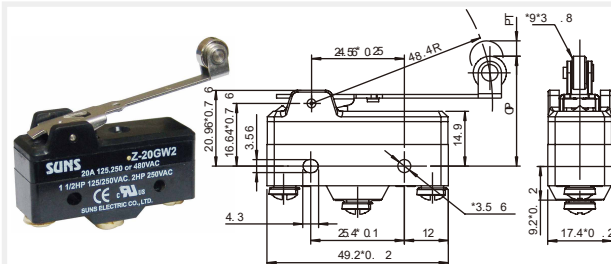

Z-20GW2 & Z-25GW2 Operating Characteristics

● CF(Max)	0.97 N	● OT(Min)	1.52 mm
● RF(Min)	0.14 N	● MD(Max)	2.16mm
● PT(Max)	11.9mm	● CP	30.2*0.8mm

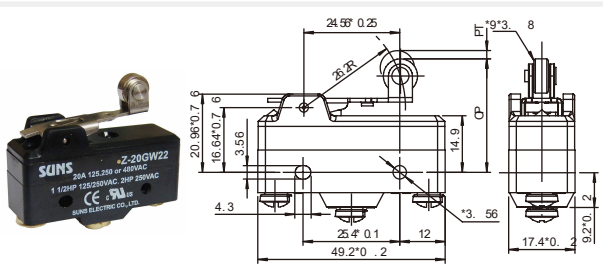

Z-20GW22 & Z-25GW22 Operating Characteristics

● CF(Max)	1.67N	● OT(Min)	0.76mm
● RF(Min)	0.42N	● MD(Max)	1.14mm
● PT(Max)	6.35mm	● CP	30.2*0.8mm

GENERAL-PURPOSE MICRO SWITCHES Z-20,Z-25 SERIES

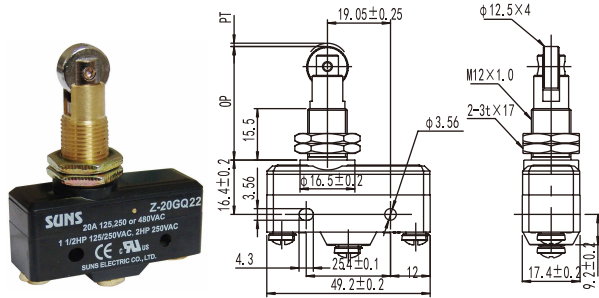

Z-20GQ22 & Z-25GQ22

Operating Characteristics

- | | | | |
|------------|------------|------------|------------|
| ● OF | 3.89~6.11N | ● OT (Min) | 3.58mm |
| ● RF (Min) | 2.78N | ● MD | 0.05~0.2mm |
| ● PT (Max) | 1.3mm | ● OP | 33.4±1.2mm |

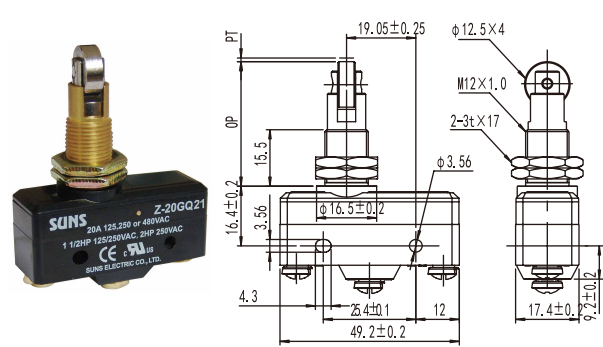

Z-20GQ21 & Z-25GQ21

Operating Characteristics

- | | | | |
|------------|------------|------------|------------|
| ● OF | 3.89~6.11N | ● OT (Min) | 3.58mm |
| ● RF (Min) | 2.78N | ● MD | 0.05~0.2mm |
| ● PT (Max) | 1.3mm | ● OP | 33.4±1.2mm |

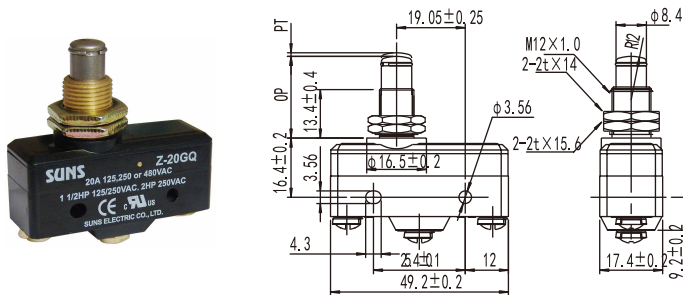

Z-20GQ & Z-25GQ

Operating Characteristics

- | | | | |
|------------|------------|------------|------------|
| ● OF | 3.89~6.11N | ● OT (Min) | 5.56mm |
| ● RF (Min) | 2.78N | ● MD | 0.05~0.2mm |
| ● PT (Max) | 1.3mm | ● OP | 21.8±0.8mm |

GENERAL-PURPOSE MICRO SWITCHES

Terminal Dimensions

Unit: mm

<p>-P0 Screw on Soldering Tab</p>	<p>-P1 Screw on Soldering Tab</p>
<p>-P2 Screw on Soldering Tab</p>	<p>-P3 Screw Terminal</p>
<p>-P4 Screw Terminal</p>	<p>-P5 Screw Terminal</p>
<p>-P6 Screw Terminal</p>	<p>-P7 Screw Terminal</p>
<p>-P8 Terminal Potted</p>	<p>-D6 QC Terminal</p>
<p>-Q2 30° QC Terminal</p>	<p>-S1 Screw Terminal</p>

GENERAL-PURPOSE MICRO SWITCHES

Reset Drawings and Pictures:

-R Standard Reset

-R1 Short Reset

-R2 Long Reset

Accessories:

ZC-1
Protective sleeve

ZC-2
Protective sleeve

<p>ZCM-A ZCM-A1</p>	<p>Protective metal enclosure</p> <p>Protective metal enclosure</p>	<p>1/2" NPT conduit</p> <p>1/2" NPS conduit</p>
---------------------------------------	---	---